

CUT LIST (XXXX-SB-2000-5600-600-R34)					
ITEM	QTY	DESCRIPTION	TH	MATERIAL	BENDS
1	1	01 OUTER TOP L	1.6	ZINC ANNEAL	9
2	1	02 OUTER TOP R	1.6	ZINC ANNEAL	11
3	1	03 OUTER BOTTOM L	1.6	ZINC ANNEAL	7
4	1	04 OUTER BOTTOM R	1.6	ZINC ANNEAL	8
5	1	05 OUTER LEFT L	1.6	ZINC ANNEAL	5
6	1	06 OUTER LEFT R	1.6	ZINC ANNEAL	5
7	1	07 OUTER RIGHT L	1.6	ZINC ANNEAL	5
8	1	08 OUTER RIGHT R	1.6	ZINC ANNEAL	5
9	2	09 OUTER MULLION 1&2	1.6	ZINC ANNEAL	2
10	1	10 OUTER MULLION 3	1.6	ZINC ANNEAL	2
11	2	11 OUTER MULLION 3&4	1.6	ZINC ANNEAL	2
12	1	12 OUTER REAR A	1.6	ZINC ANNEAL	4
13	1	13 OUTER REAR B	1.6	ZINC ANNEAL	4
14	1	14 OUTER REAR C	1.6	ZINC ANNEAL	4
15	1	15 OUTER REAR D	1.6	ZINC ANNEAL	4
16	1	16 OUTER REAR E	1.6	ZINC ANNEAL	4
17	1	17 OUTER REAR F	1.6	ZINC ANNEAL	4
18	1	18 OUTER REAR G	1.6	ZINC ANNEAL	4
19	3	19 DOOR BODY A&B&C	1.6	ZINC ANNEAL	4
20	1	20 DOOR BODY D	1.6	ZINC ANNEAL	4
21	3	21 DOOR BODY E&F&G	1.6	ZINC ANNEAL	4
22	1	22 INNER REAR A	1.6	ZINC ANNEAL	3
23	1	23 INNER REAR B	1.6	ZINC ANNEAL	3
24	1	24 INNER REAR C	1.6	ZINC ANNEAL	3
25	1	25 INNER REAR D (ETCHED)	1.6	ZINC ANNEAL	3
26	1	26 INNER REAR E (ETCHED)	1.6	ZINC ANNEAL	3
27	1	27 INNER REAR F (ETCHED)	1.6	ZINC ANNEAL	3
28	1	28 INNER REAR G (ETCHED)	1.6	ZINC ANNEAL	3
29	1	29 INNER WALL 1	1.6	ZINC ANNEAL	4
30	1	30 INNER WALL 2	1.6	ZINC ANNEAL	4
31	2	31 INNER WALL 3&4	1.6	ZINC ANNEAL	4
32	1	32 INNER LANDING A	1.6	ZINC ANNEAL	10
33	2	33 INNER LANDING B&C	1.6	ZINC ANNEAL	10
34	1	34 SHELF A1	1.6	ZINC ANNEAL	5
35	1	35 SHELF A2	1.6	ZINC ANNEAL	5
36	8	36 VENT HOOD	1.6	ZINC ANNEAL	7
37	4	37 BRACKET LIGHT	1.6	ZINC ANNEAL	4
38	4	38 BRACKET SWITCH	1.6	ZINC ANNEAL	1
39	3	39 DOOR V STIFF A&B&C	1.5	ZINC ANNEAL	4
40	4	40 DOOR V STILL D&E&F&G	1.5	ZINC ANNEAL	4
41	14	41 DOOR H STIFF	1.5	ZINC ANNEAL	4
42	1	42 ESCUTCHEON A1	1.5	ZINC ANNEAL	6
43	1	43 ESCUTCHEON A2	1.5	ZINC ANNEAL	6
44	1	44 ESCUTCHEON A3	1.5	ZINC ANNEAL	6
45	2	45 ESCUTCHEON B&C	1.5	ZINC ANNEAL	5
46	1	46 TOPHAT 1	2	GALVANISED - RAW	4
47	1	47 TOPHAT 2	2	GALVANISED - RAW	4
48	6	48 TOPHAT 3	2	GALVANISED - RAW	4
49	1	49 BRACKET ARRESTOR	2	GALVANISED - RAW	1
50	7	50 GLAND PLATE	3	ALUMINIUM - RAW	0
51	1	51 STIFFENER FLAT 25X5 X 1995L		MILD STEEL	
52	4	***XXXX-SB-TFI-MPANEL***	2.5	GALVANISED - RAW	4
53	32	BOLT M8X40		MILD STEEL	

REV	DESCRIPTION	DATE	BY
C			
B			
A			
-	INITIAL RELEASE	29/08/22	LF
APV2	APPROVAL RELEASE	25/08/22	LF
REV	DESCRIPTION	DATE	BY

NAME	DATE
DRAWN LF	25/08/22
CHK'D DR	25/08/22
APPV'D GC	29/08/22

UNLESS OTHERWISE SPECIFIED  
DIMENSIONS ARE IN MILLIMETERS  
TOLERANCES:  
LINEAR: ±1mm  
ANGULAR: ±1°  
REMOVE ALL SHARP EDGES & BURRS

MATERIAL: AS SHOWN  
FINISH: AS SHOWN

DO NOT SCALE DRAWING

**Rowlands  
Metal Works**

QUALITY CRAFTSMANSHIP  
SINCE 1956

Unit 13/19 Heath St.  
Lonsdale SA 5160  
p +61 (08) 8329 6700  
f +61 (08) 8329 6701  
metal@rowlandsmetal.com.au  
www.rowlandsmetal.com.au  
ABN 33 674 549 964

CUSTOMER:  
XXXXX  
PROJECT:  
TFI MURRAY BRIDGE PHOENIX PROJECT  
DRAWING:  
XXXX-SB-2000-5600-600-R34  
SHEET NAME:  
CUT LIST

REV: -  
A3

SHEET 1 OF 11

**FOR PRODUCTION**

**DESIGN**

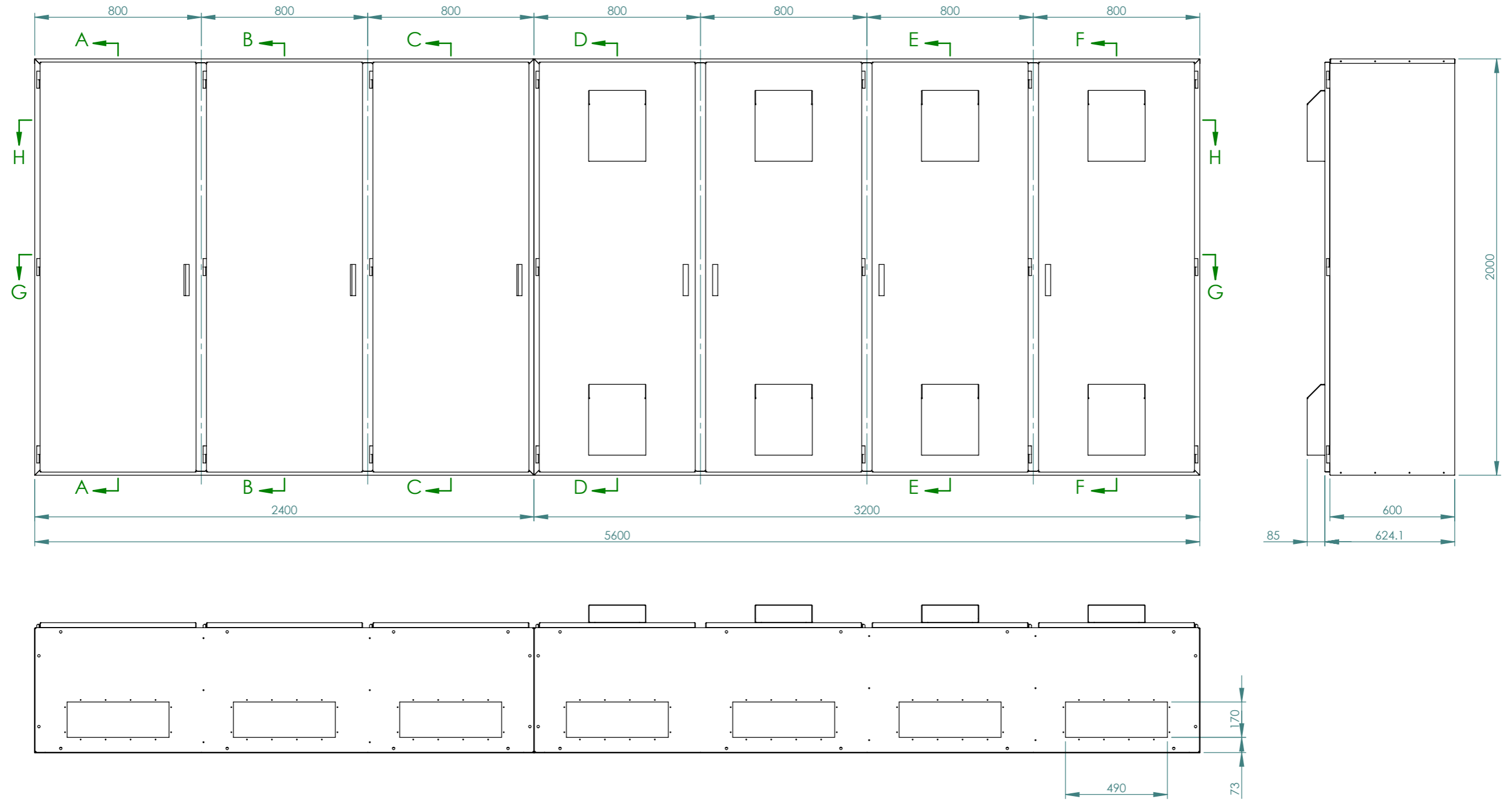

REV	DESCRIPTION	DATE	BY
C			
B			
A			
-	INITIAL RELEASE	29/08/22	LF
APV2	APPROVAL RELEASE	25/08/22	LF
REV	DESCRIPTION	DATE	BY

**FOR PRODUCTION**



MATERIAL:	AS SHOWN
FINISH:	AS SHOWN
DO NOT SCALE DRAWING	

UNLESS OTHERWISE SPECIFIED  
DIMENSIONS ARE IN MILLIMETERS  
TOLERANCES:  
LINEAR: ±1mm  
ANGULAR: ±1°  
REMOVE ALL SHARP EDGES & BURRS



**Rowlands Metal Works**  
QUALITY CRAFTSMANSHIP  
SINCE 1956  
Unit 13/19 Heath St.  
Lonsdale SA 5160  
p +61 (08) 8329 6700  
F +61 (08) 8329 6701  
metal@rowlandsmetal.com.au  
www.rowlandsmetal.com.au  
ABN 33 674 549 964

CUSTOMER:	XXXX
PROJECT:	TFI MURRAY BRIDGE PHOENIX PROJECT
DRAWING:	XXXX-SB-2000-5600-600-R34
SHEET NAME:	DESIGN 1
REV:	-
A3	
SHEET 2 OF 11	

# DESIGN

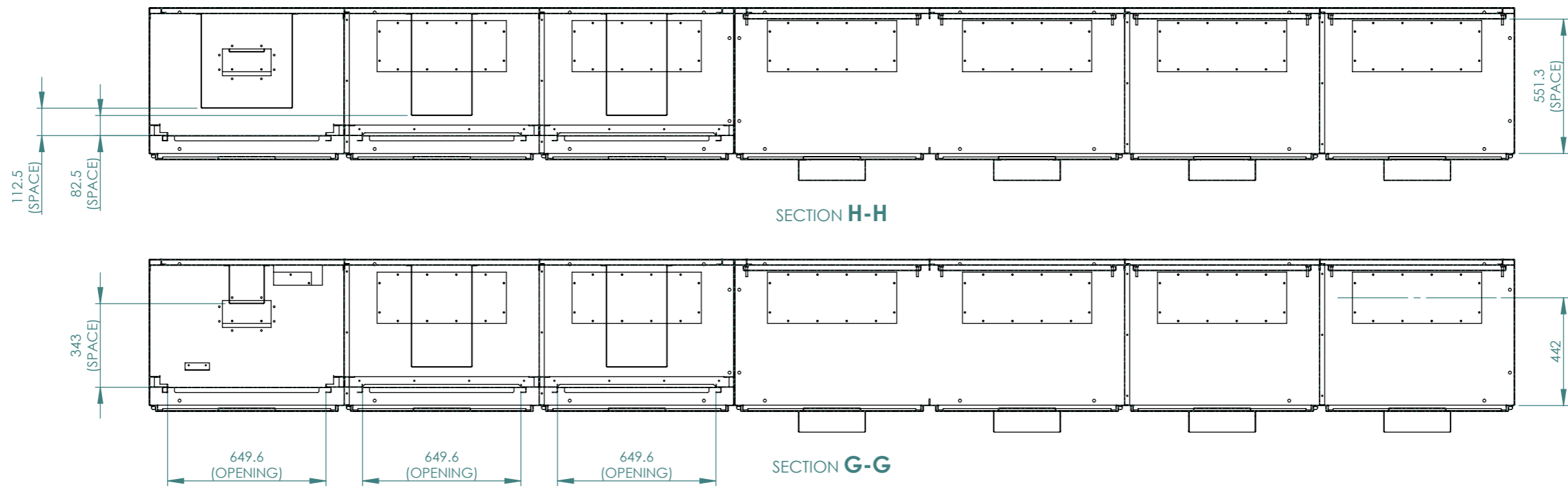
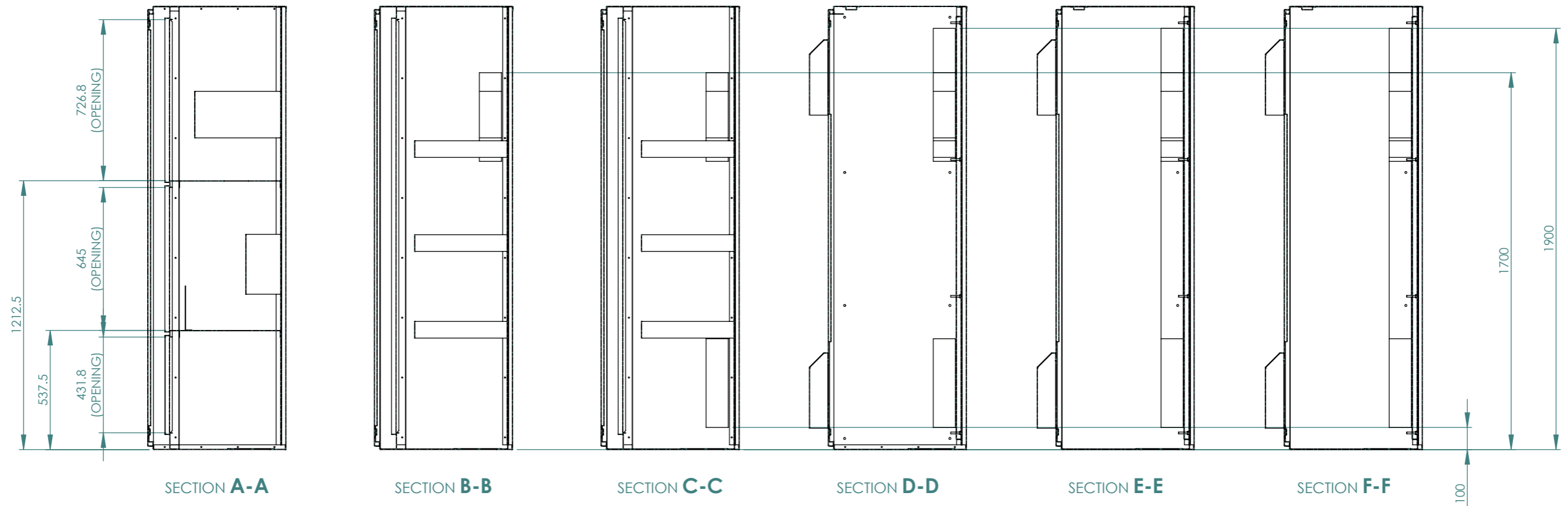

REV	DESCRIPTION	DATE	BY
C			
B			
A			
-	INITIAL RELEASE	29/08/22	LF
APV2	APPROVAL RELEASE	25/08/22	LF
REV	DESCRIPTION	DATE	BY

UNLESS OTHERWISE SPECIFIED  
DIMENSIONS ARE IN MILLIMETERS  
TOLERANCES:  
LINEAR: ±1mm  
ANGULAR: ±1°  
REMOVE ALL SHARP EDGES & BURRS

MATERIAL: AS SHOWN  
FINISH: AS SHOWN  
DO NOT SCALE DRAWING



**Rowlands Metal Works**  
QUALITY CRAFTSMANSHIP SINCE 1956  
Unit 13/19 Heath St.  
Lonsdale SA 5160  
p +61 (08) 8329 6700  
f +61 (08) 8329 6701  
metal@rowlandsmetal.com.au  
www.rowlandsmetal.com.au  
ABN 33 674 549 964

CUSTOMER: XXXX	REV: -	A3
PROJECT: TFI MURRAY BRIDGE PHOENIX PROJECT	SHEET 3 OF 11	
DRAWING: XXXX-SB-2000-5600-600-R34	DESIGN 2	

**FOR PRODUCTION**

**DESIGN**

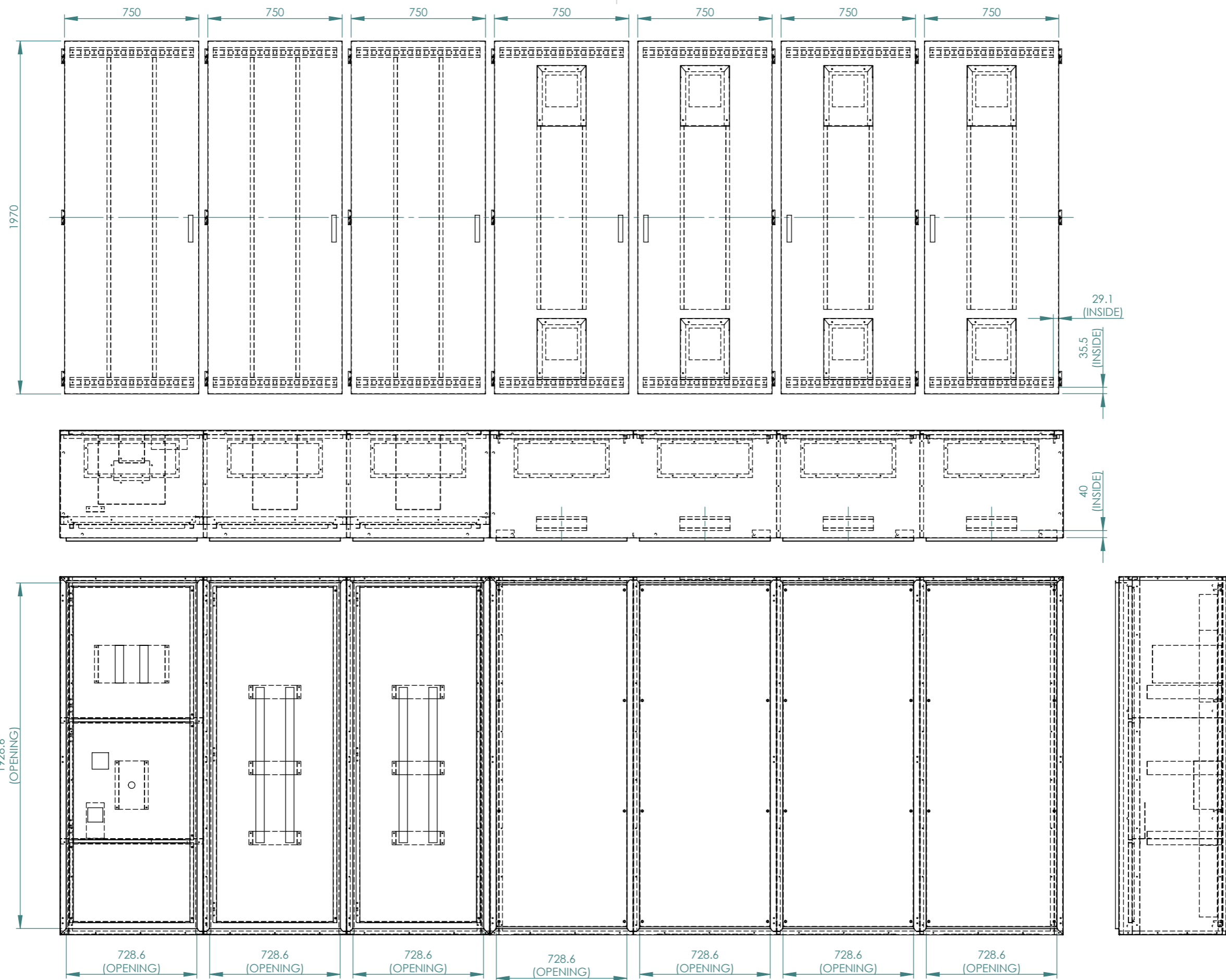

REV	DESCRIPTION	DATE	BY
APV2	APPROVAL RELEASE	25/08/22	LF
-	INITIAL RELEASE	29/08/22	LF

NAME	DATE
DR	25/08/22
GC	29/08/22

UNLESS OTHERWISE SPECIFIED  
DIMENSIONS ARE IN MILLIMETERS  
TOLERANCES:  
LINEAR: ±1mm  
ANGULAR: ±1°  
REMOVE ALL SHARP EDGES & BURRS

MATERIAL: AS SHOWN  
FINISH: AS SHOWN

DO NOT SCALE DRAWING

**FOR PRODUCTION**



**Rowlands Metal Works**  
QUALITY CRAFTSMANSHIP SINCE 1956  
Unit 13/19 Heath St.  
Lonsdale SA 5160  
p +61 (08) 8329 6700  
f +61 (08) 8329 6701  
metal@rowlandsmetal.com.au  
www.rowlandsmetal.com.au  
ABN 33 674 549 964

CUSTOMER: XXXX	PROJECT: TFI MURRAY BRIDGE PHOENIX PROJECT	REV: -	A3
DRAWING: XXXX-SB-2000-5600-600-R34	SHEET NAME: DESIGN 3	SHEET 4 OF 11	

# CONSTRUCTION NOTES

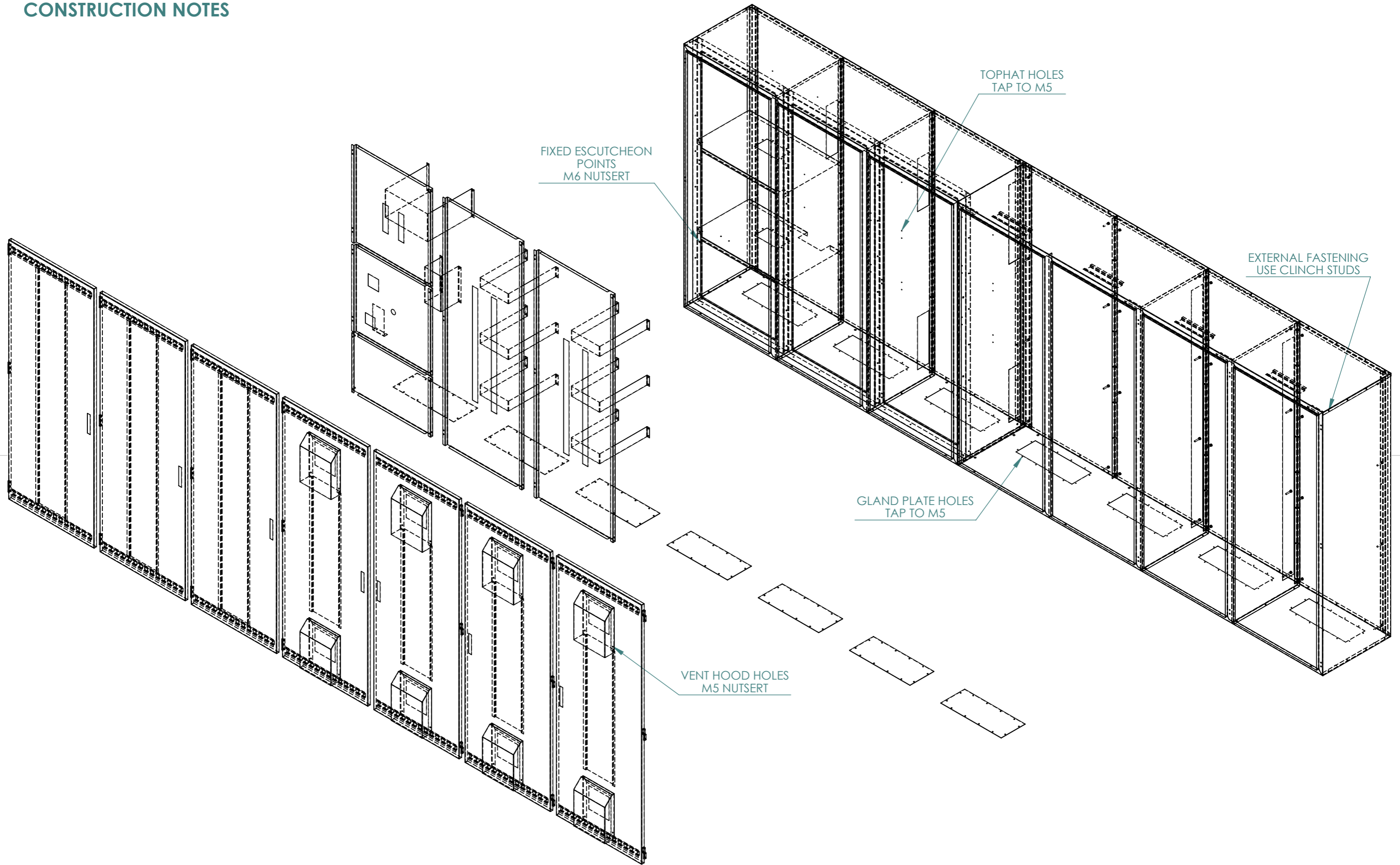

REV	DESCRIPTION	DATE	BY
APV2	APPROVAL RELEASE	25/08/22	LF
-	INITIAL RELEASE	29/08/22	LF

NAME	DATE
DR	25/08/22
GC	29/08/22

UNLESS OTHERWISE SPECIFIED  
DIMENSIONS ARE IN MILLIMETERS  
TOLERANCES:  
LINEAR: ±1mm  
ANGULAR: ±1°  
REMOVE ALL SHARP EDGES & BURRS

MATERIAL: AS SHOWN  
FINISH: AS SHOWN  
DO NOT SCALE DRAWING

**FOR PRODUCTION**



**Rowlands Metal Works**  
QUALITY CRAFTSMANSHIP SINCE 1956  
Unit 13/19 Heath St.  
Lonsdale SA 5160  
p +61 (08) 8329 6700  
F +61 (08) 8329 6701  
metal@rowlandsmetal.com.au  
www.rowlandsmetal.com.au  
ABN 33 674 549 964

CUSTOMER: XXXX  
PROJECT: TFI MURRAY BRIDGE PHOENIX PROJECT  
DRAWING: XXXX-SB-2000-5600-600-R34  
SHEET NAME: CON NOTES

REV: -  
A3  
SHEET 5 OF 11

# FINISHING NOTES

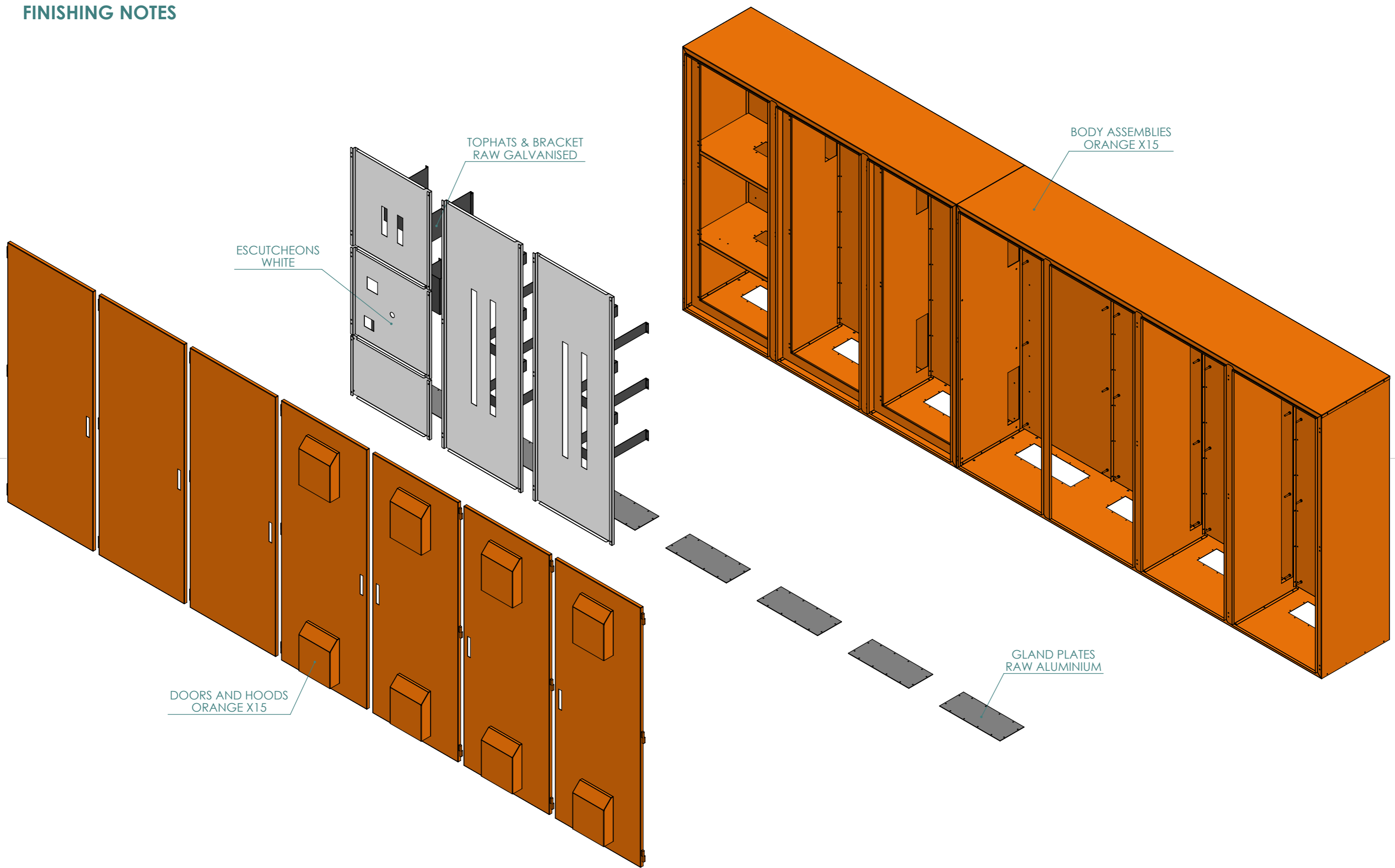

REV	DESCRIPTION	DATE	BY
C			
B			
A			
-	INITIAL RELEASE	29/08/22	LF
APV2	APPROVAL RELEASE	25/08/22	LF
REV	DESCRIPTION	DATE	BY

UNLESS OTHERWISE SPECIFIED  
DIMENSIONS ARE IN MILLIMETERS  
TOLERANCES:  
LINEAR: ±1mm  
ANGULAR: ±1°  
REMOVE ALL SHARP EDGES & BURRS

MATERIAL: AS SHOWN  
FINISH: AS SHOWN  
DO NOT SCALE DRAWING

**FOR PRODUCTION**



**Rowlands Metal Works**  
QUALITY CRAFTSMANSHIP SINCE 1956  
Unit 13/19 Heath St.  
Lonsdale SA 5160  
p +61 (08) 8329 6700  
f +61 (08) 8329 6701  
metal@rowlandsmetal.com.au  
www.rowlandsmetal.com.au  
ABN 33 674 549 964

CUSTOMER: XXXX  
PROJECT: TFI MURRAY BRIDGE PHOENIX PROJECT  
DRAWING: XXXX-SB-2000-5600-600-R34  
SHEET NAME: FIN NOTES

REV: -  
A3  
SHEET 6 OF 11

**ITEM PROFILES**

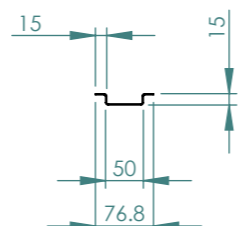
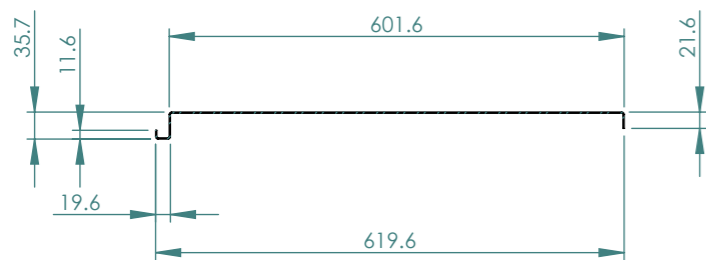

ITEM #37

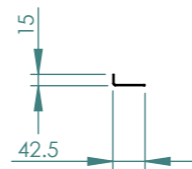

ITEM #38

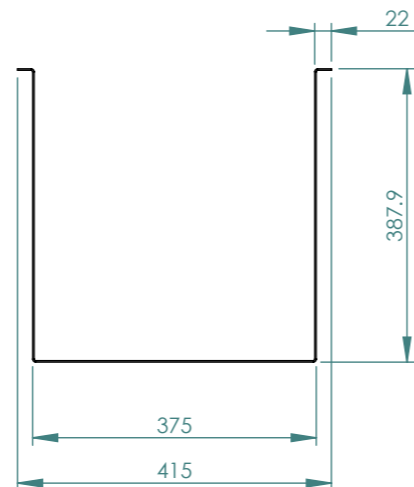

ITEM #46

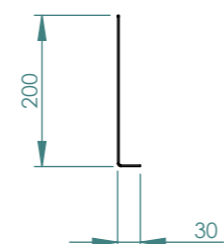

ITEM #49

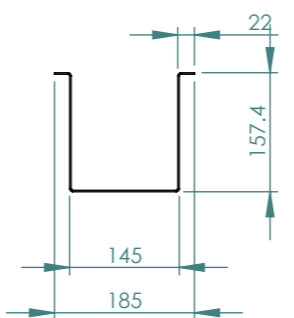
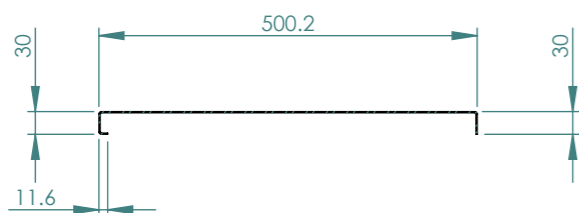

ITEM #47

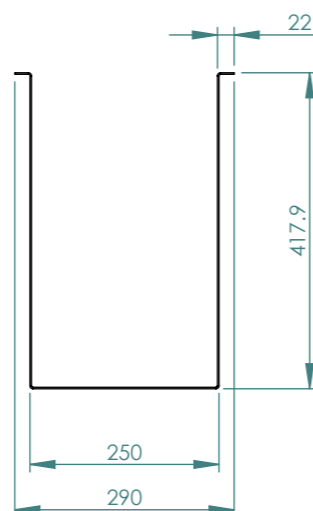

ITEM #48

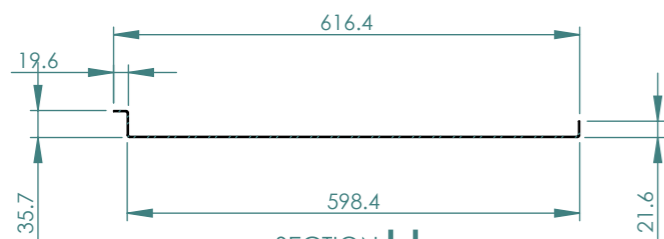
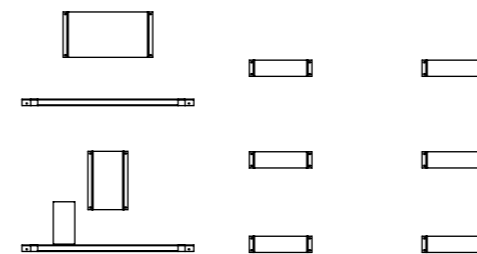
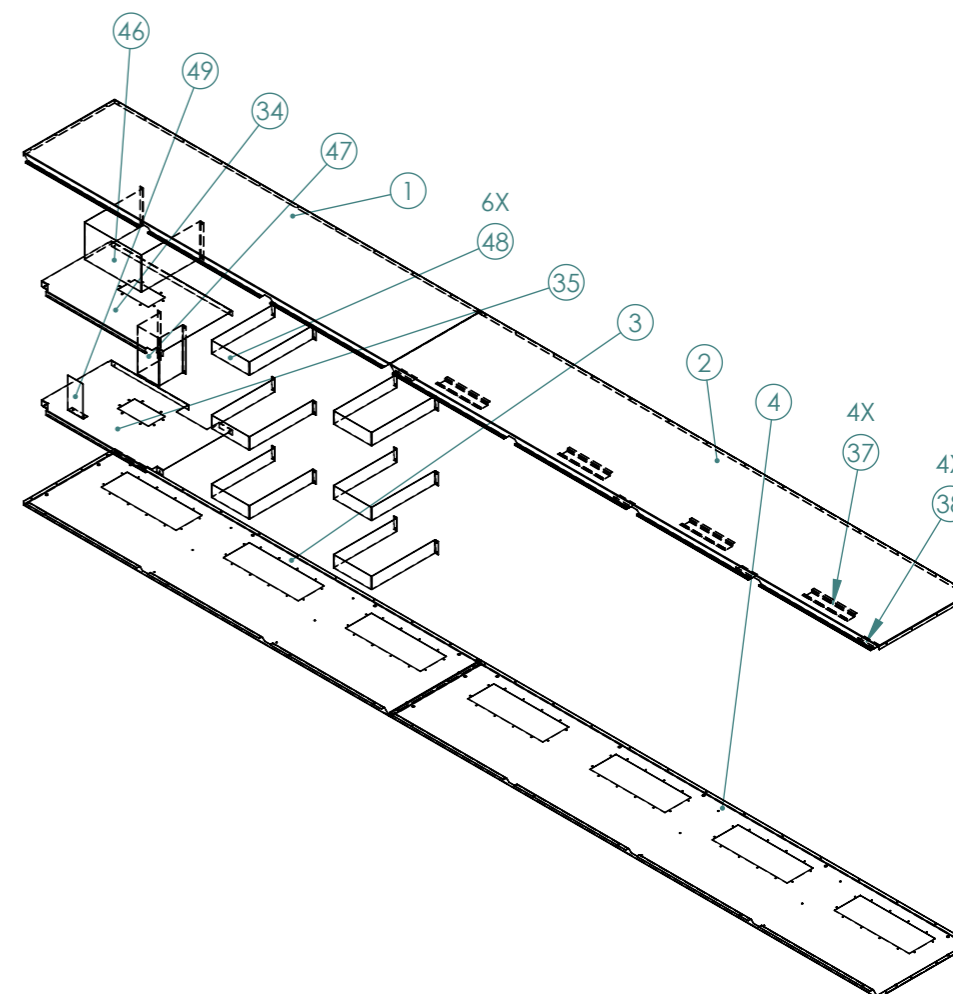

SECTION I-I

REV	DESCRIPTION	DATE	BY
C			
B			
A			
-	INITIAL RELEASE	29/08/22	LF
APV2	APPROVAL RELEASE	25/08/22	LF
REV	DESCRIPTION	DATE	BY

**FOR PRODUCTION**



UNLESS OTHERWISE SPECIFIED  
DIMENSIONS ARE IN MILLIMETERS  
TOLERANCES:  
LINEAR: ±1mm  
ANGULAR: ±1°  
REMOVE ALL SHARP EDGES & BURRS

MATERIAL: AS SHOWN  
FINISH: AS SHOWN  
DO NOT SCALE DRAWING



**Rowlands Metal Works**  
QUALITY CRAFTSMANSHIP  
SINCE 1956

Unit 13/19 Heath St.  
Lonsdale SA 5160  
p +61 (08) 8329 6700  
f +61 (08) 8329 6701  
metal@rowlandsmetal.com.au  
www.rowlandsmetal.com.au  
ABN 33 674 549 964

CUSTOMER: XXXX  
PROJECT: TFI MURRAY BRIDGE PHOENIX PROJECT  
DRAWING: XXXX-SB-2000-5600-600-R34  
SHEET NAME: ITEMS 1

REV: -  
A3  
SHEET 7 OF 11

# ITEM PROFILES

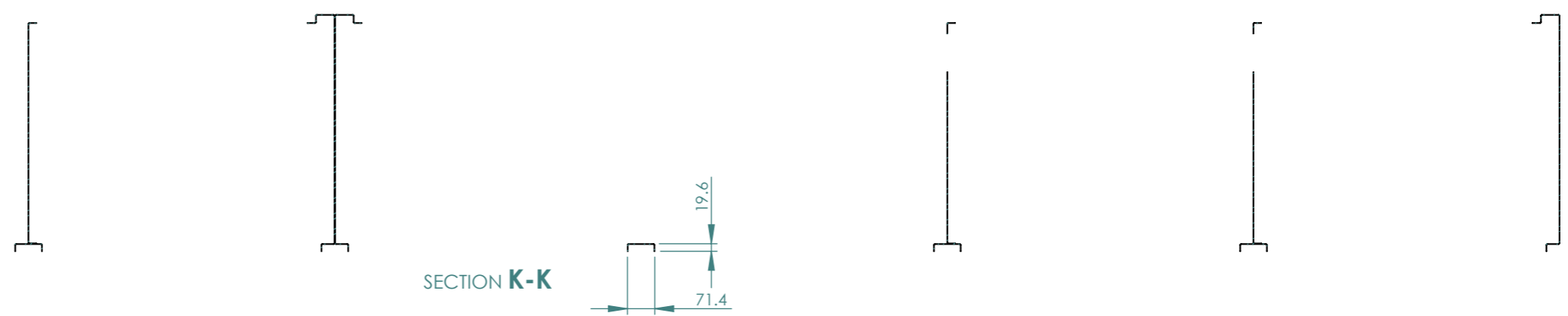
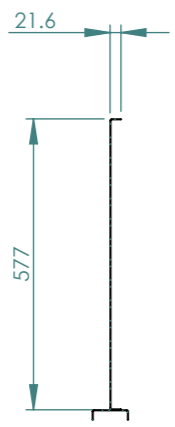
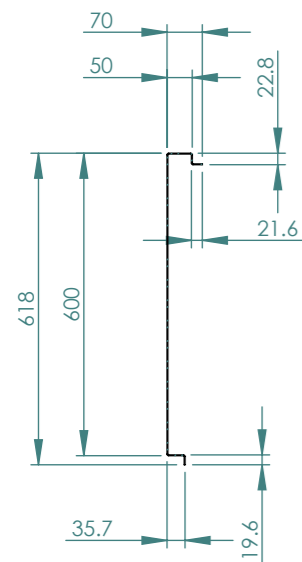
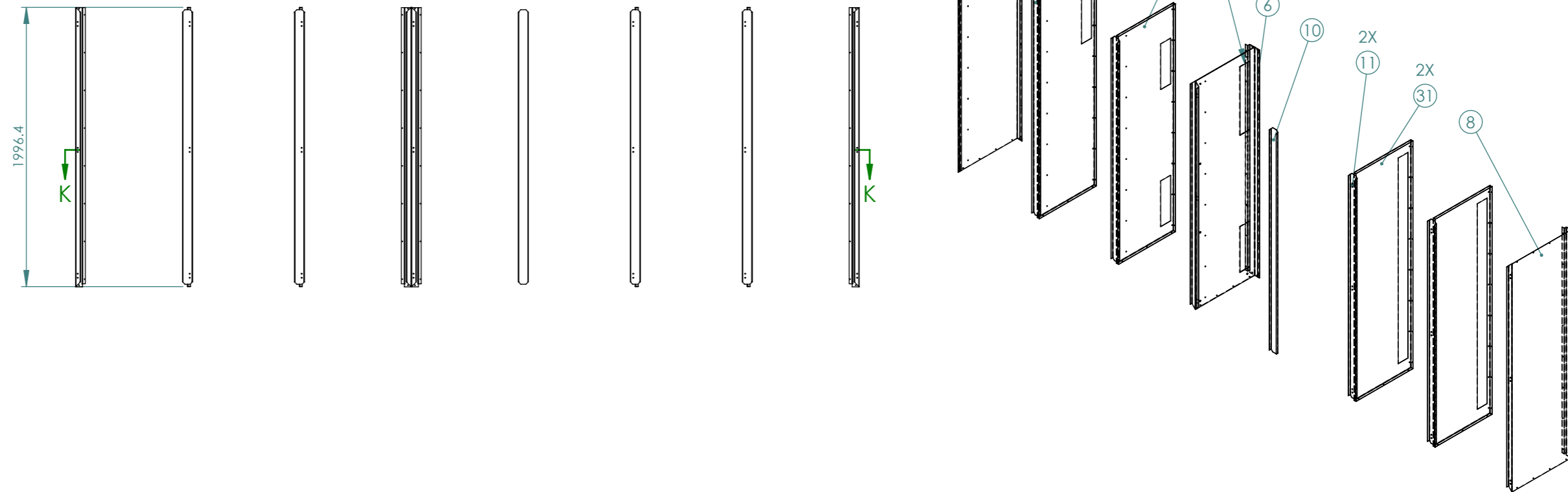

REV	DESCRIPTION	DATE	BY
APV2	APPROVAL RELEASE	25/08/22	LF
-	INITIAL RELEASE	29/08/22	LF

UNLESS OTHERWISE SPECIFIED  
DIMENSIONS ARE IN MILLIMETERS  
TOLERANCES:  
LINEAR: ±1mm  
ANGULAR: ±1°  
REMOVE ALL SHARP EDGES & BURRS

MATERIAL: AS SHOWN  
FINISH: AS SHOWN  
DO NOT SCALE DRAWING



**Rowlands Metal Works**  
QUALITY CRAFTSMANSHIP SINCE 1956  
Unit 13/19 Heath St.  
Lonsdale SA 5160  
p +61 (08) 8329 6700  
f +61 (08) 8329 6701  
metal@rowlandsmetal.com.au  
www.rowlandsmetal.com.au  
ABN 33 674 549 964

CUSTOMER: XXXX	PROJECT: TFI MURRAY BRIDGE PHOENIX PROJECT	DRAWING: XXXX-SB-2000-5600-600-R34	REV: -	A3
SHEET NAME: ITEMS 2			SHEET 8 OF 11	



# ITEM PROFILES

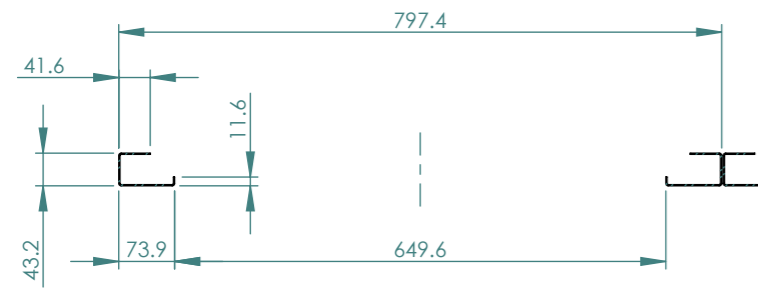
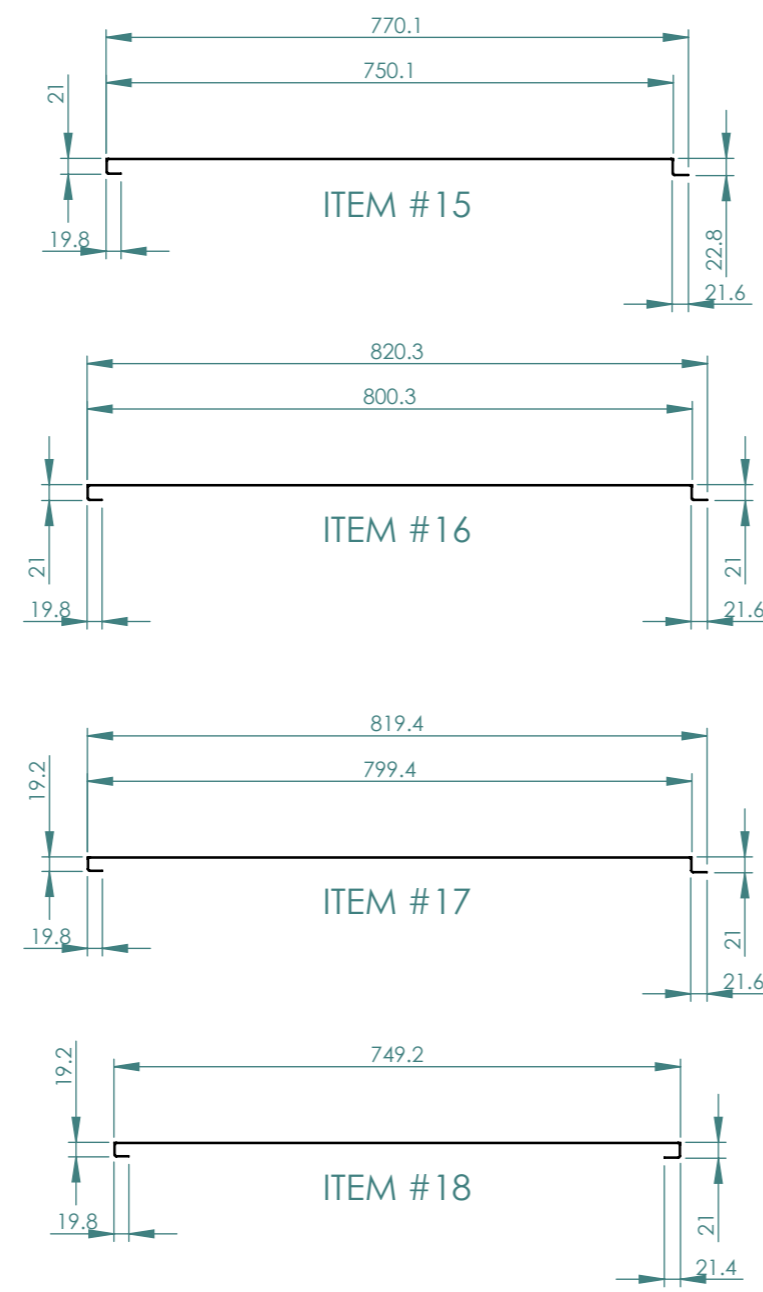
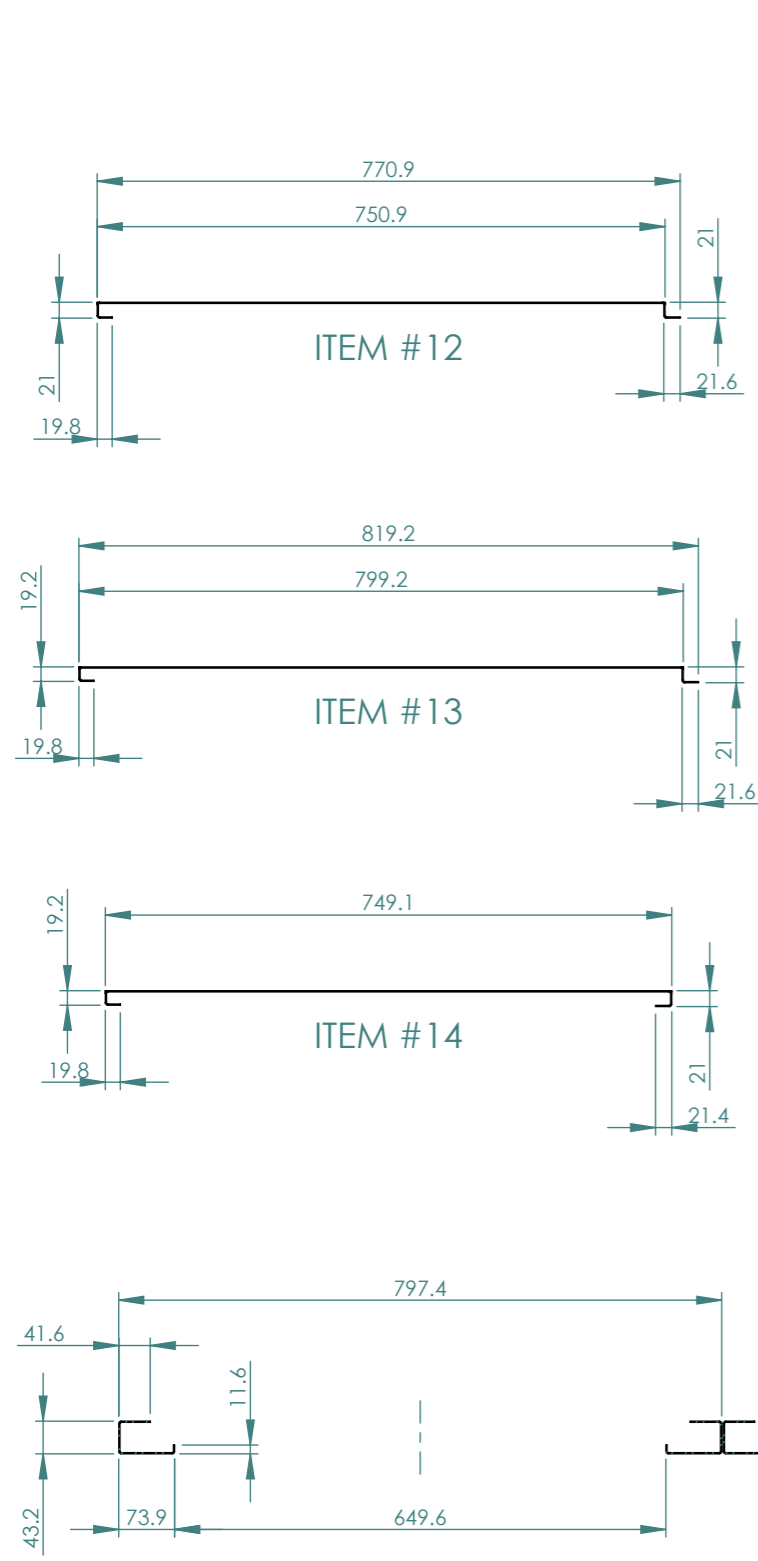

SECTION M-M

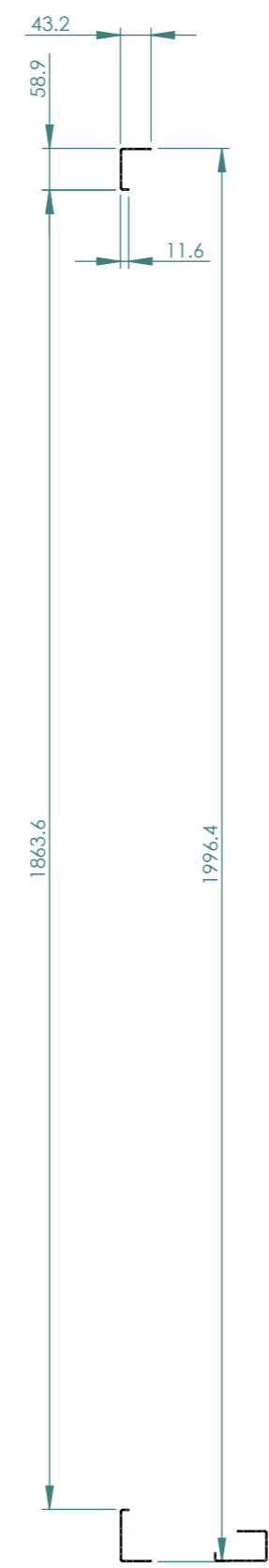

SECTION L-L

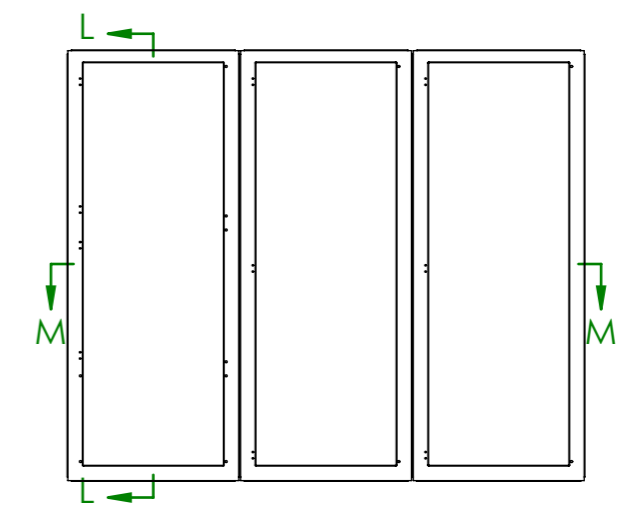
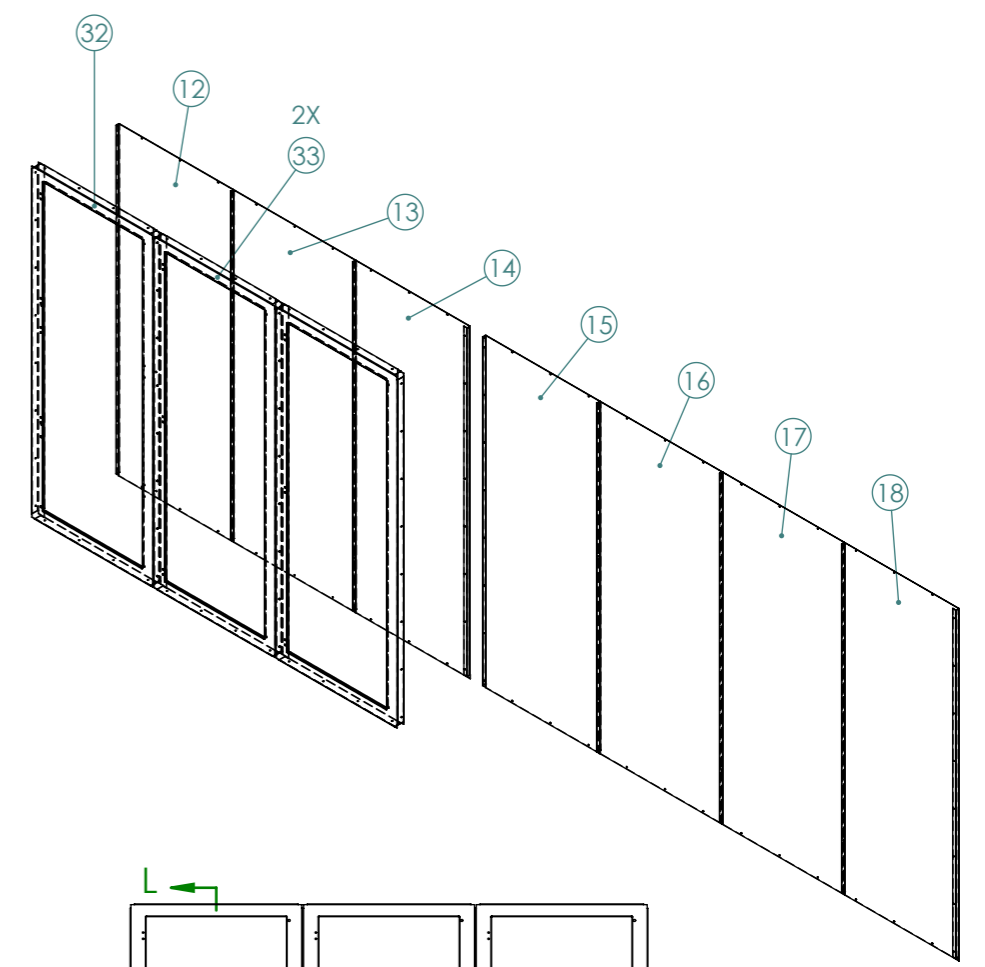

REV	DESCRIPTION	DATE	BY
C			
B			
A			
-	INITIAL RELEASE	29/08/22	LF
APV2	APPROVAL RELEASE	25/08/22	LF
REV	DESCRIPTION	DATE	BY

UNLESS OTHERWISE SPECIFIED  
DIMENSIONS ARE IN MILLIMETERS  
TOLERANCES:  
LINEAR: ±1mm  
ANGULAR: ±1°  
REMOVE ALL SHARP EDGES & BURRS

MATERIAL: AS SHOWN  
FINISH: AS SHOWN  
DO NOT SCALE DRAWING

**FOR PRODUCTION**



**Rowlands Metal Works**  
QUALITY CRAFTSMANSHIP SINCE 1956  
Unit 13/19 Heath St.  
Lonsdale SA 5160  
p +61 (08) 8329 6700  
f +61 (08) 8329 6701  
metal@rowlandsmetal.com.au  
www.rowlandsmetal.com.au  
ABN 33 674 549 964

CUSTOMER: XXXX	REV: -	A3
PROJECT: TFI MURRAY BRIDGE PHOENIX PROJECT	SHEET 9 OF 11	
DRAWING: XXXX-SB-2000-5600-600-R34		
SHEET NAME: ITEMS 3		

# ITEM PROFILES

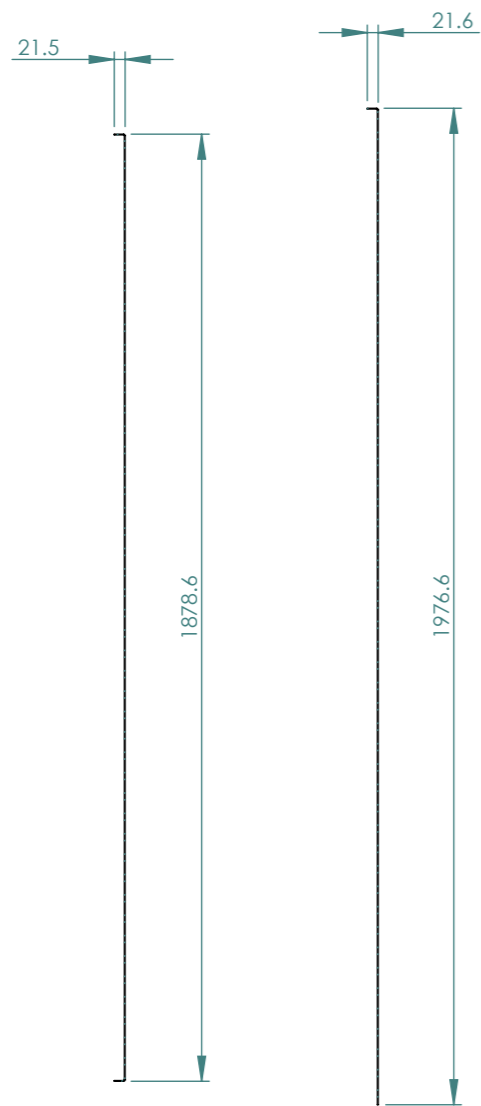

SECTION O-O

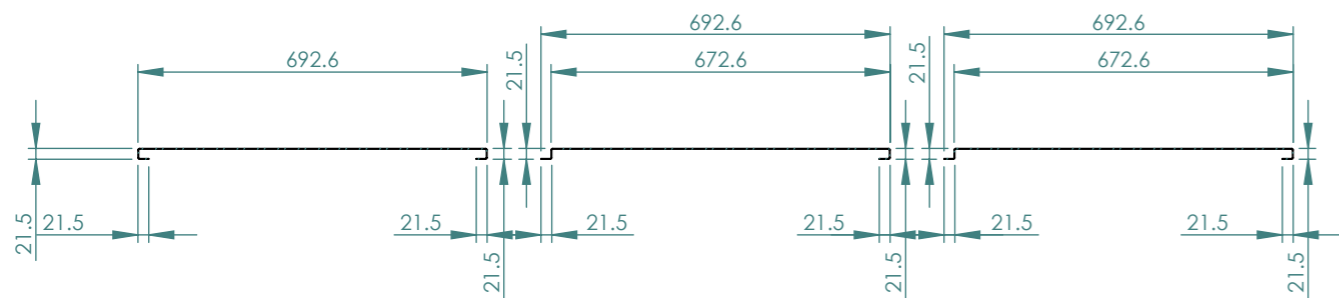
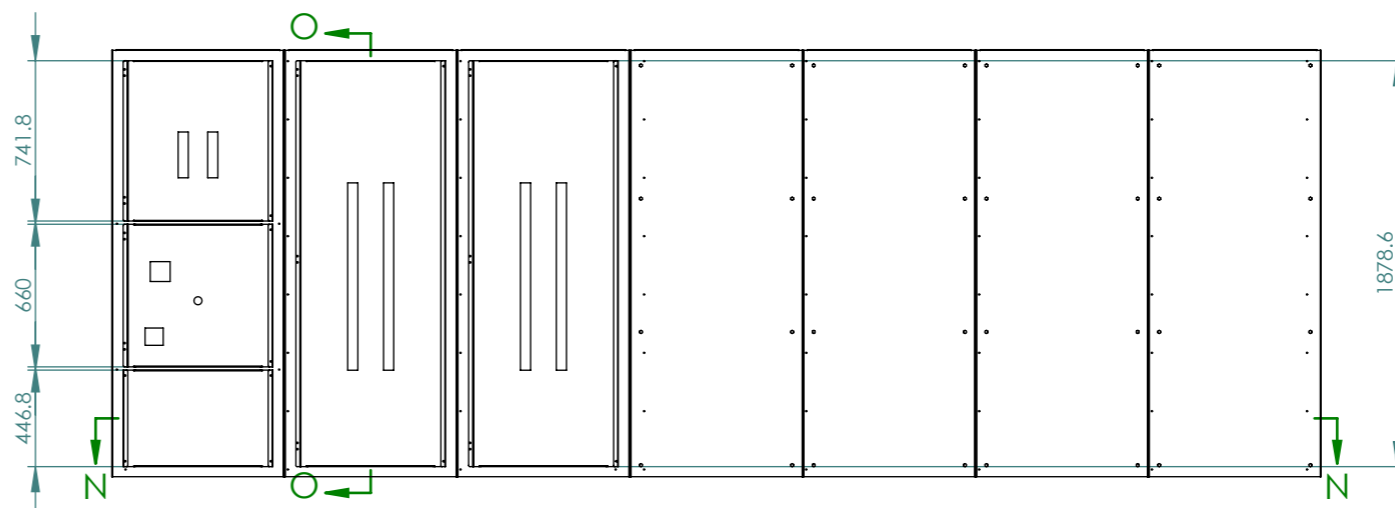
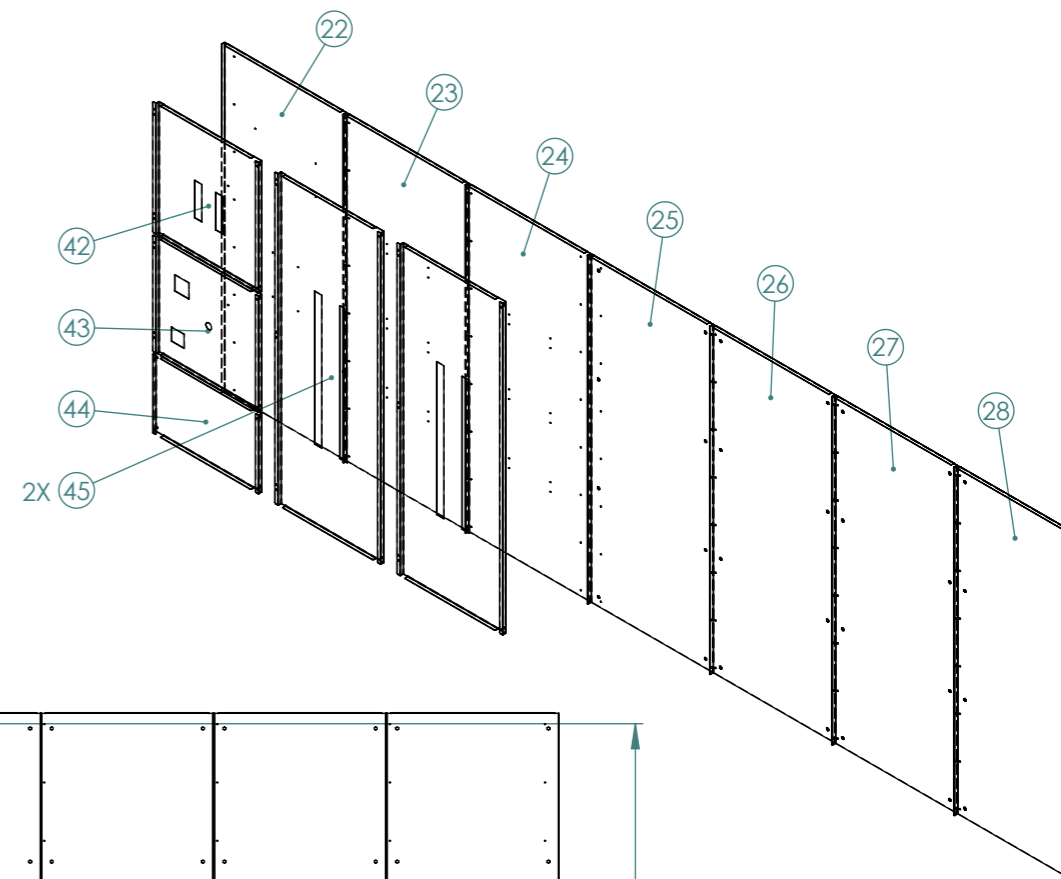

SECTION N-N

REV	DESCRIPTION	DATE	BY
C			
B			
A			
-	INITIAL RELEASE	29/08/22	LF
APV2	APPROVAL RELEASE	25/08/22	LF
REV	DESCRIPTION	DATE	BY

**FOR PRODUCTION**



MATERIAL:	AS SHOWN
FINISH:	AS SHOWN
DO NOT SCALE DRAWING	

UNLESS OTHERWISE SPECIFIED  
DIMENSIONS ARE IN MILLIMETERS  
TOLERANCES:  
LINEAR: ±1mm  
ANGULAR: ±1°  
REMOVE ALL SHARP EDGES & BURRS



**Rowlands  
Metal Works**  
QUALITY  
CRAFTSMANSHIP  
SINCE 1956

Unit 13/19 Heath St.  
Lonsdale SA 5160  
p +61 (08) 8329 6700  
F +61 (08) 8329 6701  
metal@rowlandsmetal.com.au  
www.rowlandsmetal.com.au  
ABN 33 674 549 964

CUSTOMER:	XXXX
PROJECT:	TFI MURRAY BRIDGE PHOENIX PROJECT
DRAWING:	XXXX-SB-2000-5600-600-R34
SHEET NAME:	ITEMS 4

REV: -  
A3  
SHEET 10 OF 11

# ITEM PROFILES

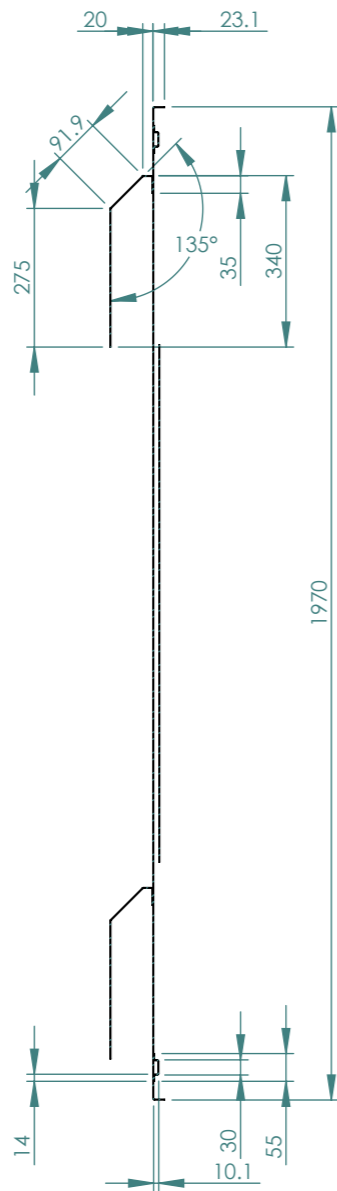

SECTION Q-Q

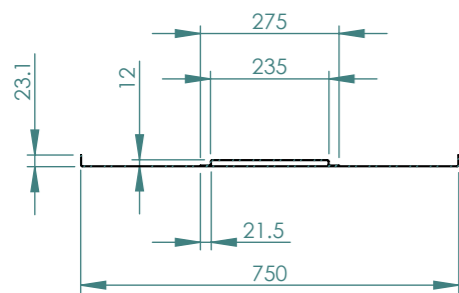

SECTION P-P

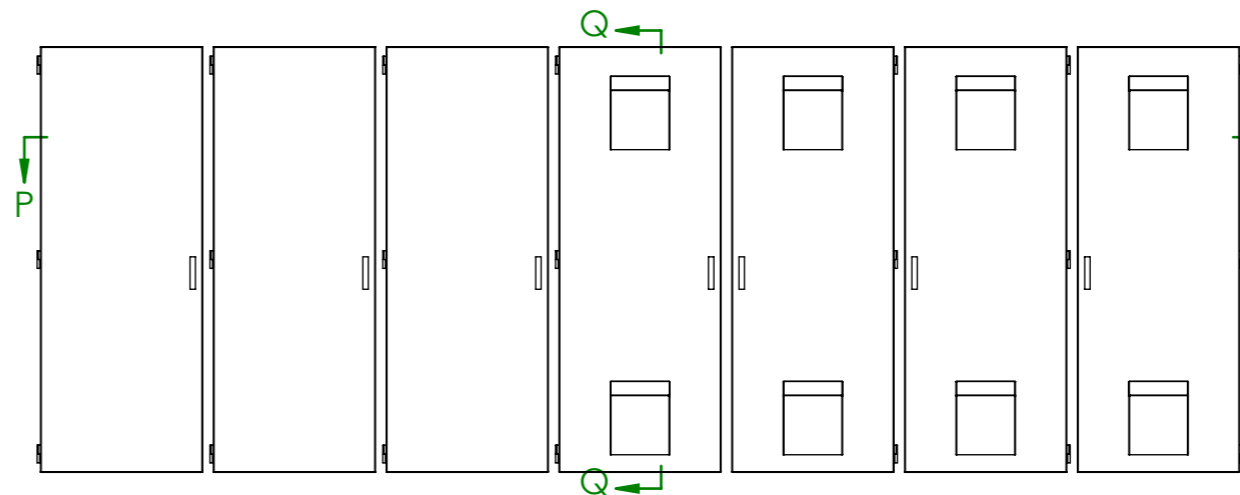
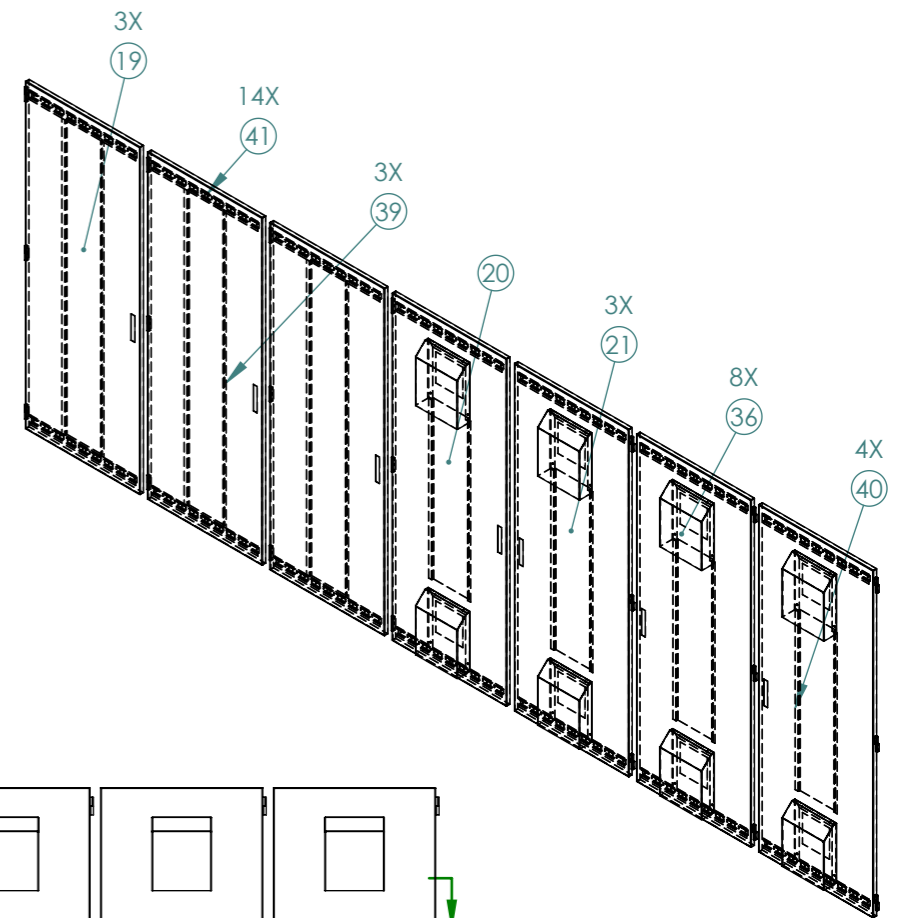

REV	DESCRIPTION	DATE	BY
C			
B			
A			
-	INITIAL RELEASE	29/08/22	LF
APV2	APPROVAL RELEASE	25/08/22	LF
REV	DESCRIPTION	DATE	BY

**FOR PRODUCTION**



UNLESS OTHERWISE SPECIFIED  
DIMENSIONS ARE IN MILLIMETERS  
TOLERANCES:  
LINEAR: ±1mm  
ANGULAR: ±1°  
REMOVE ALL SHARP EDGES & BURRS

MATERIAL: AS SHOWN  
FINISH: AS SHOWN  
DO NOT SCALE DRAWING



**Rowlands Metal Works**  
QUALITY CRAFTSMANSHIP  
SINCE 1956

Unit 13/19 Heath St.  
Lonsdale SA 5160  
p +61 (08) 8329 6700  
f +61 (08) 8329 6701  
metal@rowlandsmetal.com.au  
www.rowlandsmetal.com.au  
ABN 33 674 549 964

CUSTOMER: XXXX  
PROJECT: TFI MURRAY BRIDGE PHOENIX PROJECT  
DRAWING: XXXX-SB-2000-5600-600-R34  
SHEET NAME: ITEMS 5

REV: -  
A3  
SHEET 11 OF 11