

XXXXXX XXXX XXXXXX - OPV KITCHEN GALLEY
235 - OFFICER'S PANTRY BENCH

ITEM	QTY	DESCRIPTION	NOTE
1	1	XXXXX-OPV-SHIP5-3-235-A-FRAME	
2	1	XXXXX-OPV-SHIP5-3-235-A-SHEET	
A	1	A PANEL HORIZ (235)	
B	1	B PANEL HORIZ (235)	
C	1	C PANEL HORIZ (235)	
D	1	D PANEL SHELF HORIZ (235)	2 ITEMS
E	1	E PANEL VERT (235)	
F	1	F PANEL VERT (235)	
G	1	G PANEL VERT (235)	
H	1	H SHELF (235)	
I	1	I DOOR (235)	2 ITEMS
J	1	J DOOR (235)	2 ITEMS
K	2	K DRAWER (235)	3 ITEMS + RUNNER BRACKETS

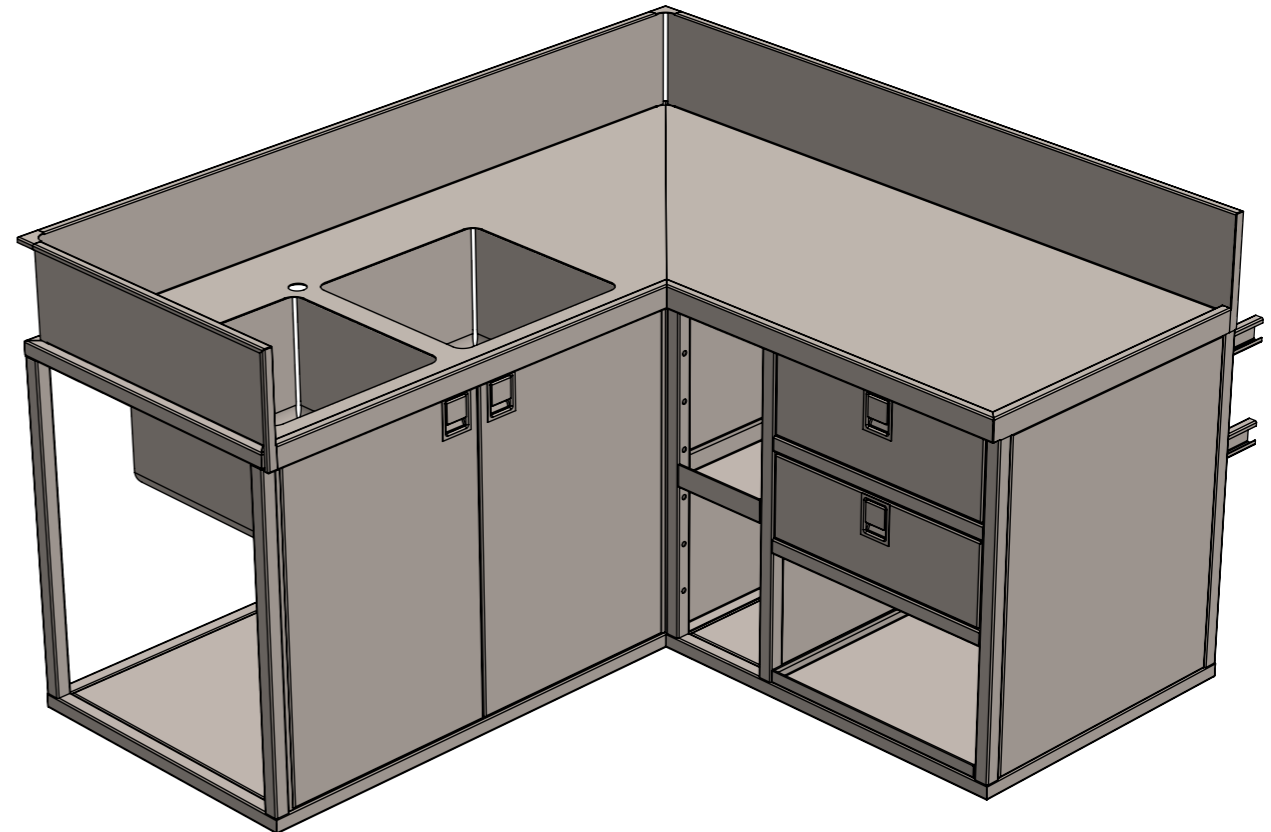
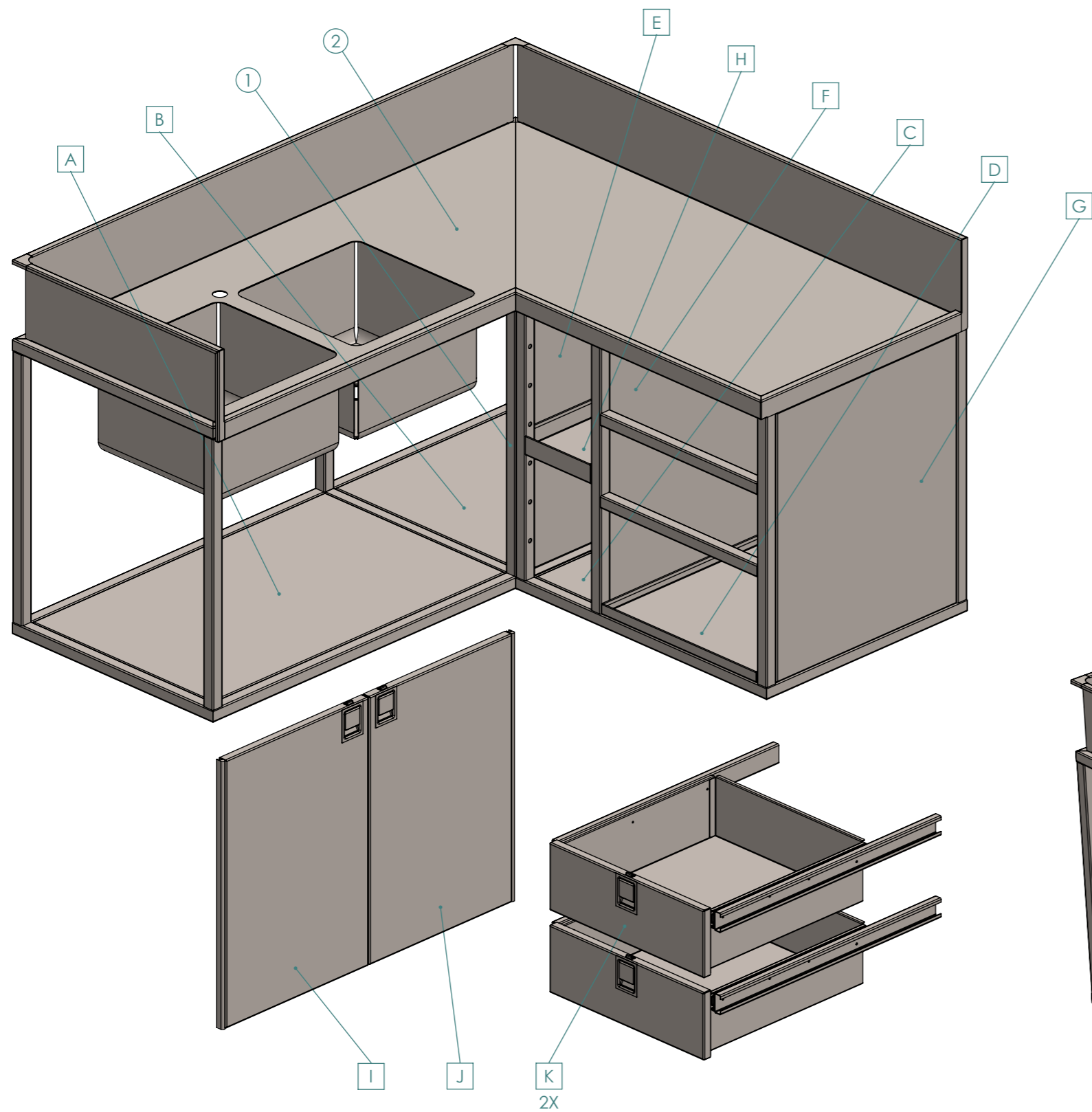

REV	DESCRIPTION	DATE	BY
C			
B			
A			
-	INITIAL RELEASE	25/07/22	LF
-	APPROVAL RELEASE	25/07/22	LF

NAME	DATE
DRAWN LF	00/00/00
CHK'D AK	00/00/00
APPV'D MK	00/00/00

UNLESS OTHERWISE SPECIFIED
 DIMENSIONS ARE IN MILLIMETERS
 TOLERANCES:
 LINEAR: ±1mm
 ANGULAR: ±1°
 REMOVE ALL SHARP EDGES & BURRS

MATERIAL: AS SHOWN
 FINISH: AS SHOWN

FOR PRODUCTION

DO NOT SCALE DRAWING



Rowlands Metal Works
 QUALITY CRAFTSMANSHIP
 SINCE 1956

Unit 13/19 Heath St.
 Lonsdale SA 5160
 p +61 (08) 8329 6700
 F +61 (08) 8329 6701
 metal@rowlandsmetal.com.au
 www.rowlandsmetal.com.au
 ABN 33 674 549 964

CUSTOMER: XXXXXX XXXX XXXXXX	REV: -	A3
PROJECT: OPV KITCHEN GALLEY	SHEET 1 OF 23	
DRAWING: XXXXX-OPV-SHIP5-3-235-A		
SHEET NAME: ASSM BOM		

1 2 3 4 5 6 7 8

A

B

C

D

E

F

A

B

C

D

E

F

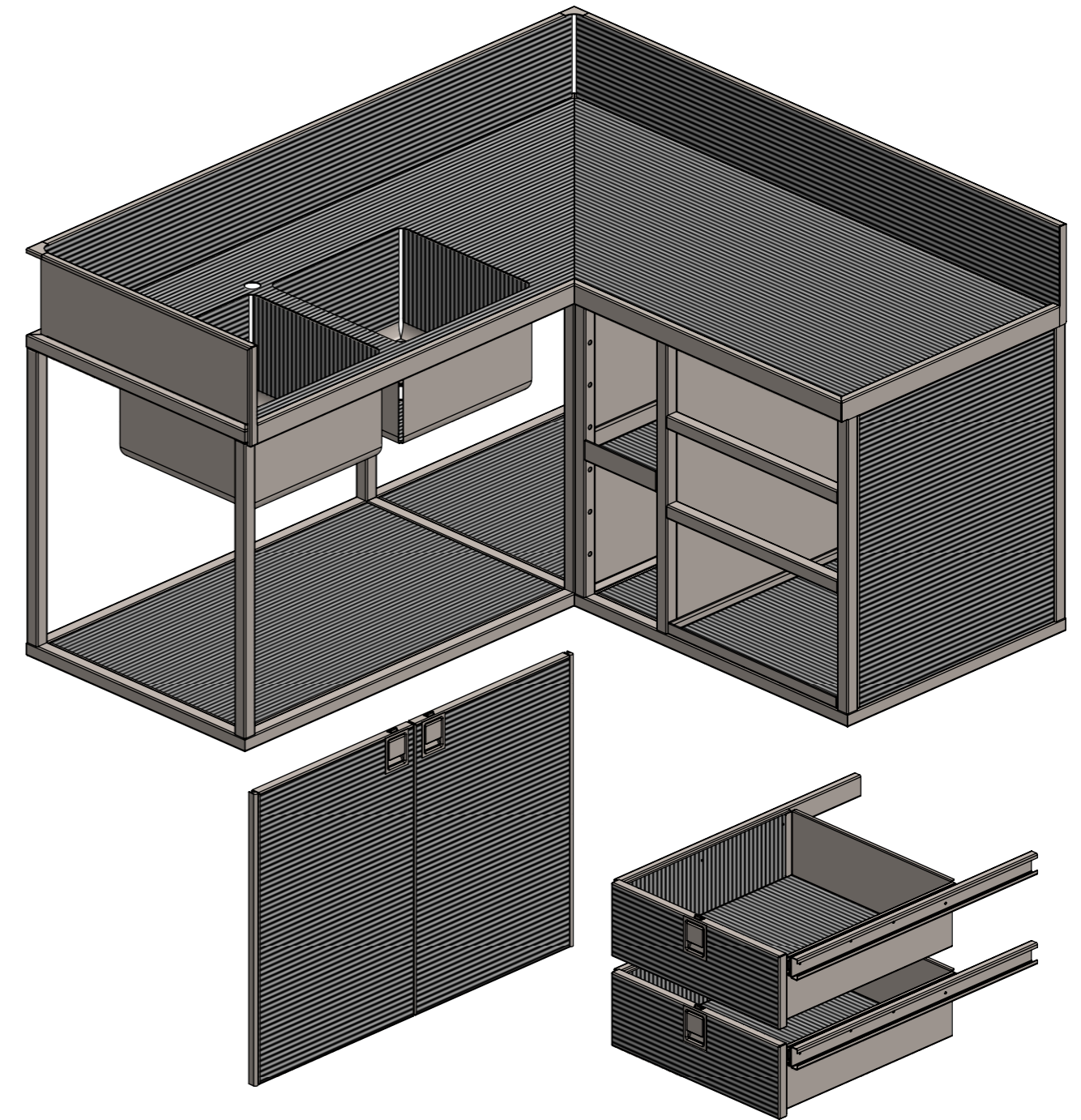
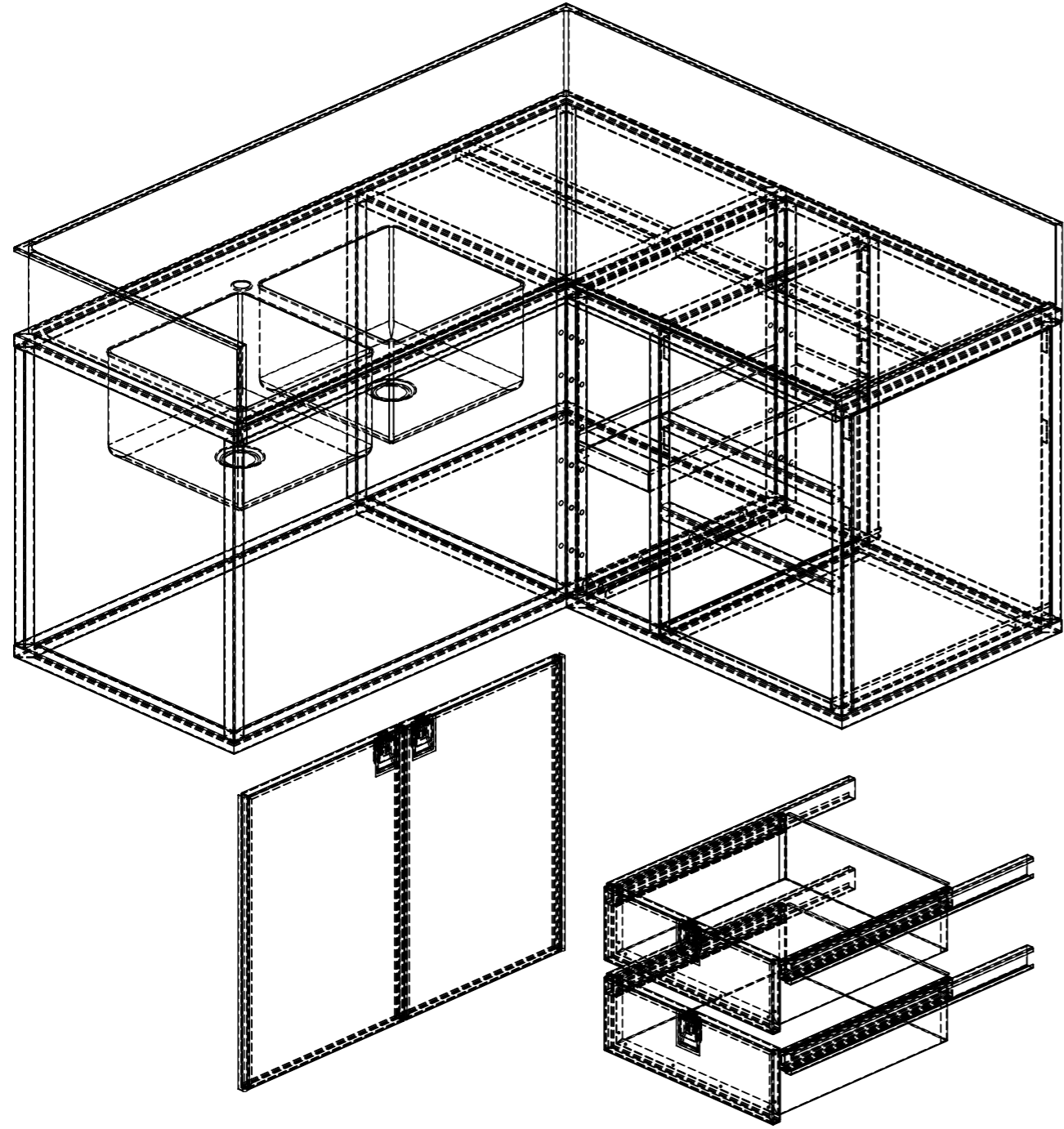

REV	DESCRIPTION	DATE	BY
-	INITIAL RELEASE	25/07/22	LF
-	APPROVAL RELEASE	25/07/22	LF

FOR PRODUCTION

UNLESS OTHERWISE SPECIFIED
DIMENSIONS ARE IN MILLIMETERS
TOLERANCES:
LINEAR: ±1mm
ANGULAR: ±1°
REMOVE ALL SHARP EDGES & BURRS



MATERIAL: AS SHOWN
FINISH: AS SHOWN
DO NOT SCALE DRAWING



**Rowlands
Metal Works**
QUALITY
CRAFTSMANSHIP
SINCE 1956

Unit 13/19 Heath St.
Lonsdale SA 5160
p +61 (08) 8329 6700
f +61 (08) 8329 6701
metal@rowlandsmetal.com.au
www.rowlandsmetal.com.au
ABN 33 674 549 964

CUSTOMER: XXXXXX XXXX XXXXXX
PROJECT: OPV KITCHEN GALLEY
DRAWING: XXXXX-OPV-SHIP5-3-235-A
SHEET NAME: ASSM REF

REV: -
A3
SHEET 2 OF 23

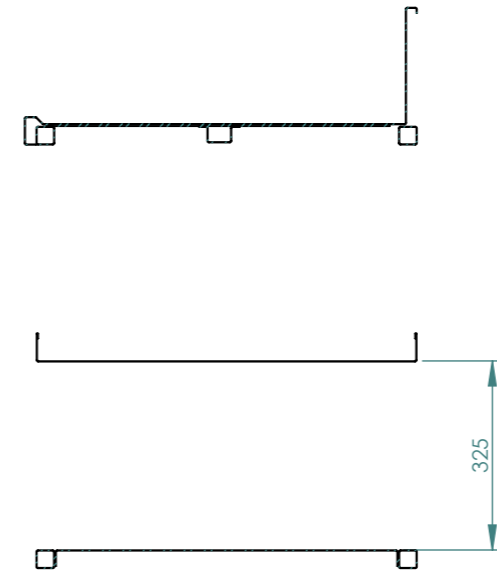
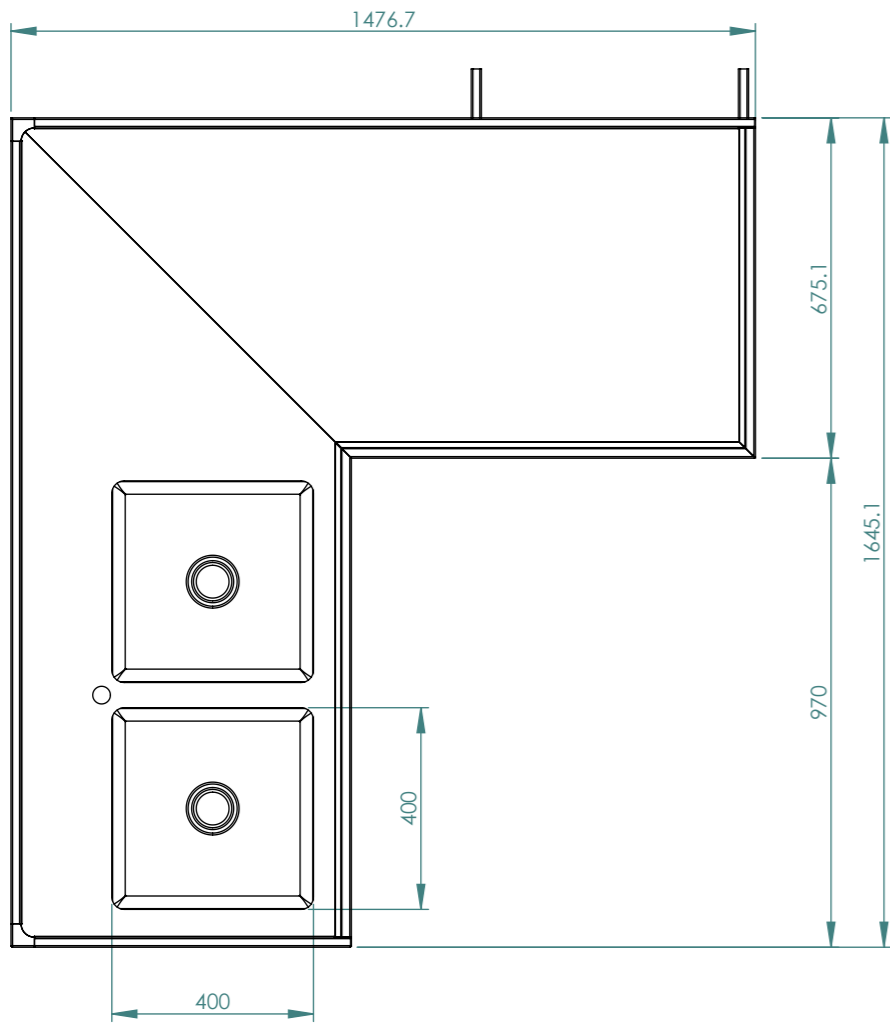

SECTION B-B

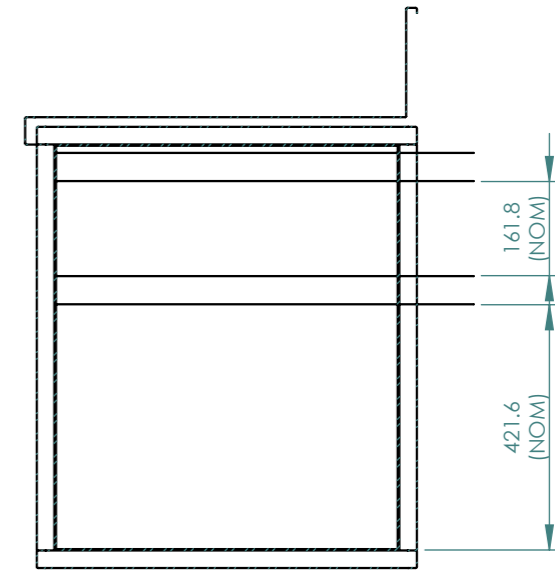

SECTION C-C

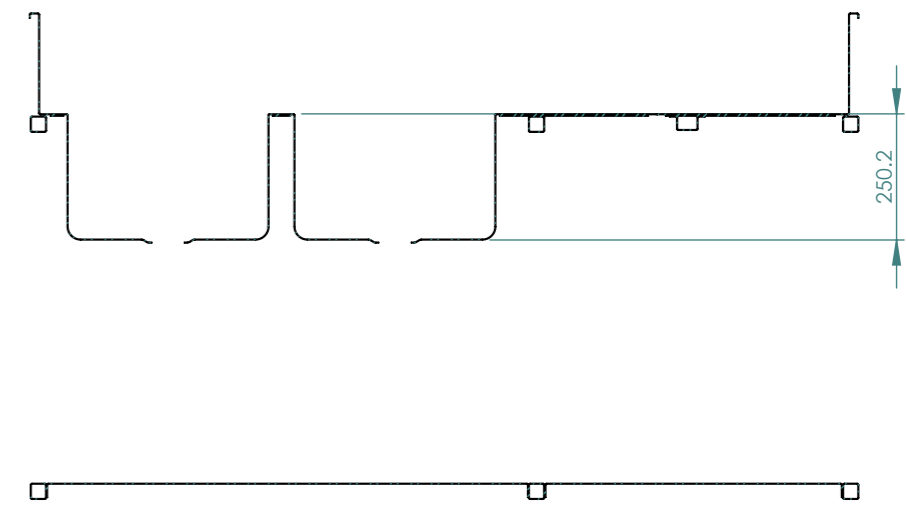
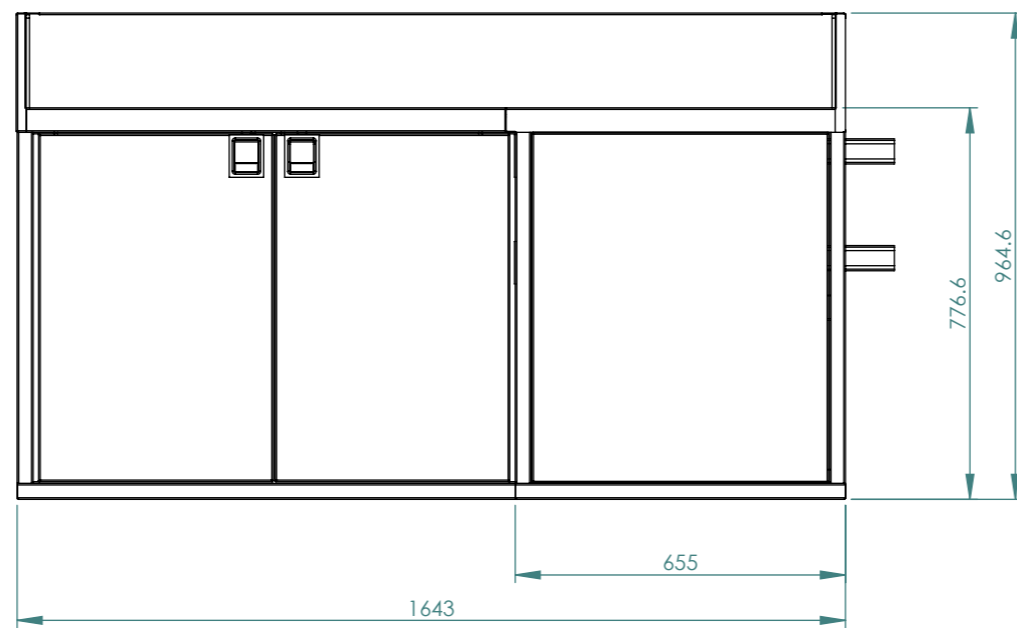
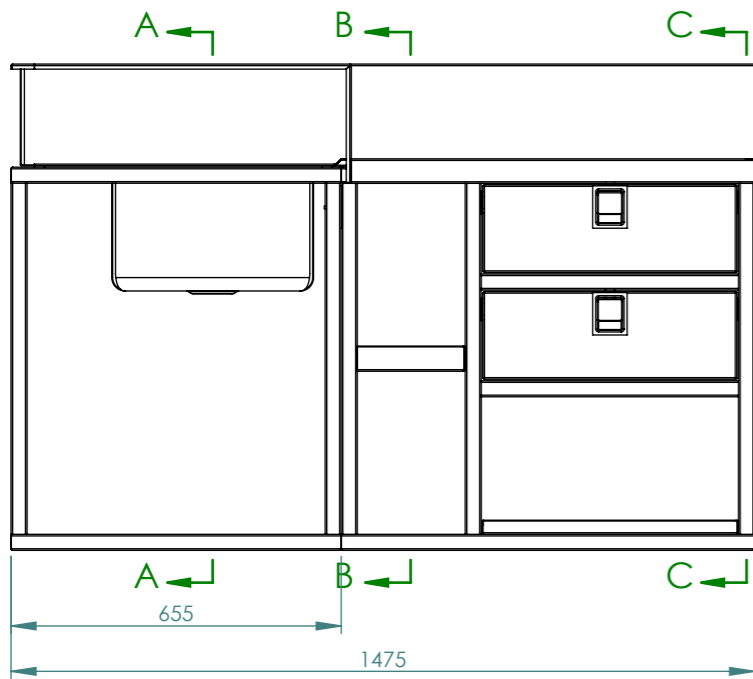

SECTION A-A

REV	DESCRIPTION	DATE	BY
C			
B			
A			
-	INITIAL RELEASE	25/07/22	LF
-	APPROVAL RELEASE	25/07/22	LF

UNLESS OTHERWISE SPECIFIED
DIMENSIONS ARE IN MILLIMETERS
TOLERANCES:
LINEAR: ±1mm
ANGULAR: ±1°
REMOVE ALL SHARP EDGES & BURRS

MATERIAL: AS SHOWN
FINISH: AS SHOWN
DO NOT SCALE DRAWING



**Rowlands
Metal Works**
QUALITY
CRAFTSMANSHIP
SINCE 1956

Unit 13/19 Heath St.
Lonsdale SA 5160
p +61 (08) 8329 6700
F +61 (08) 8329 6701
metal@rowlandsmetal.com.au
www.rowlandsmetal.com.au
ABN 33 674 549 964

CUSTOMER: XXXXXX XXXX XXXXXX	REV: -	A3
PROJECT: OPV KITCHEN GALLEY	SHEET 3 OF 23	
DRAWING: XXXXX-OPV-SHIP5-3-235-A		
SHEET NAME: ASSM DIMS		

CUT LIST (XXXXX-OPV-SHIP5-3-235-A-FRAME)				
ITEM	QTY	DESCRIPTION	LENGTH	MATERIAL
1	4	01 HORIZONTAL LONG MITRED	1643	30x30x2.0 SHS
2	4	02 HORIZONTAL MEDIUM MITRED	820	30x30x2.0 SHS
3	8	03 HORIZONTAL SHORT MITRED	655	30x30x2.0 SHS
4	4	04 HORIZONTAL	591.4	30x30x2.0 SHS
5	12	05 VERTICAL	696.4	30x30x2.0 SHS
6	2	06 DRAWER DIVIDERS	510.4	30x30x2.0 SHS

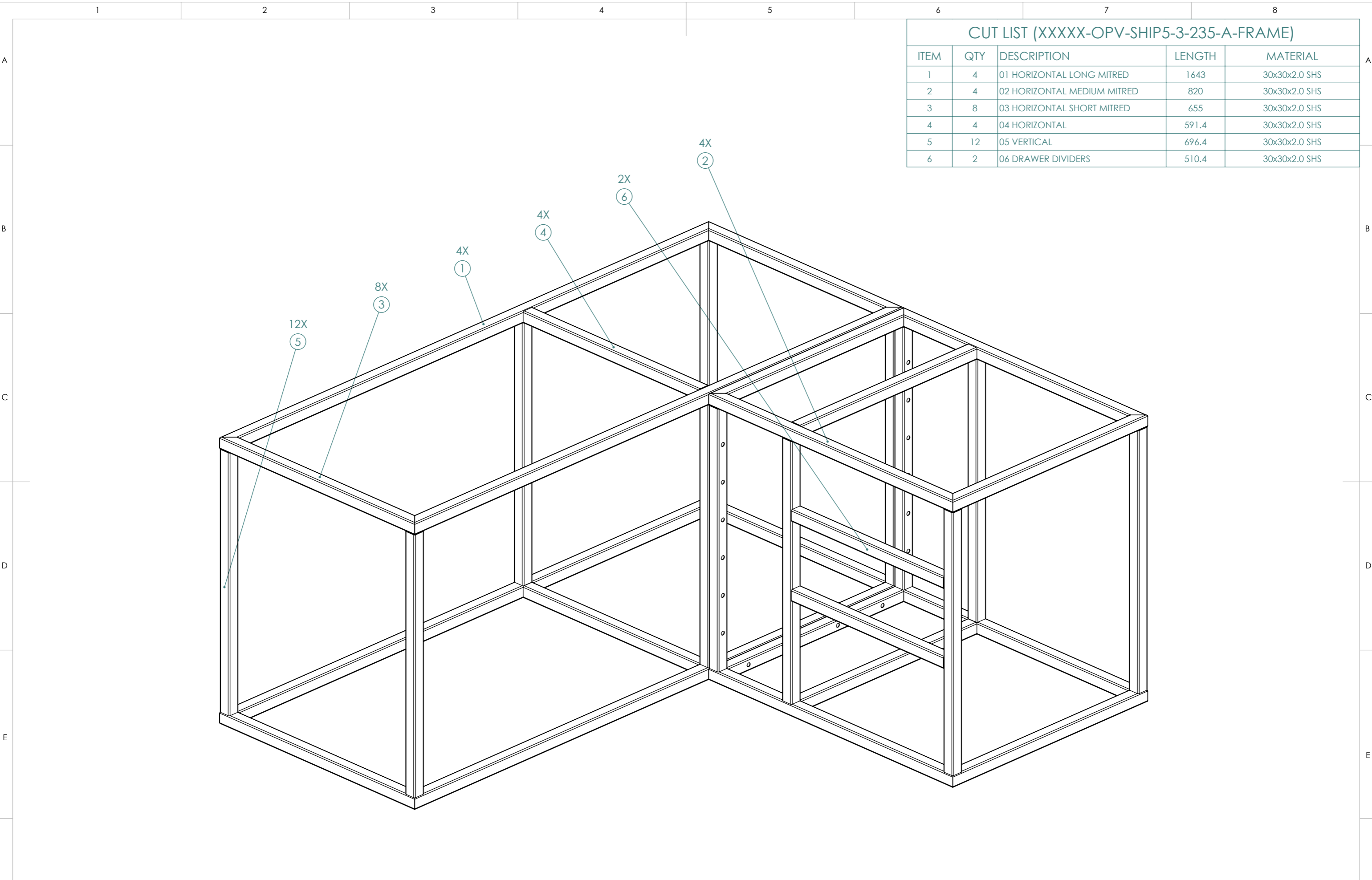
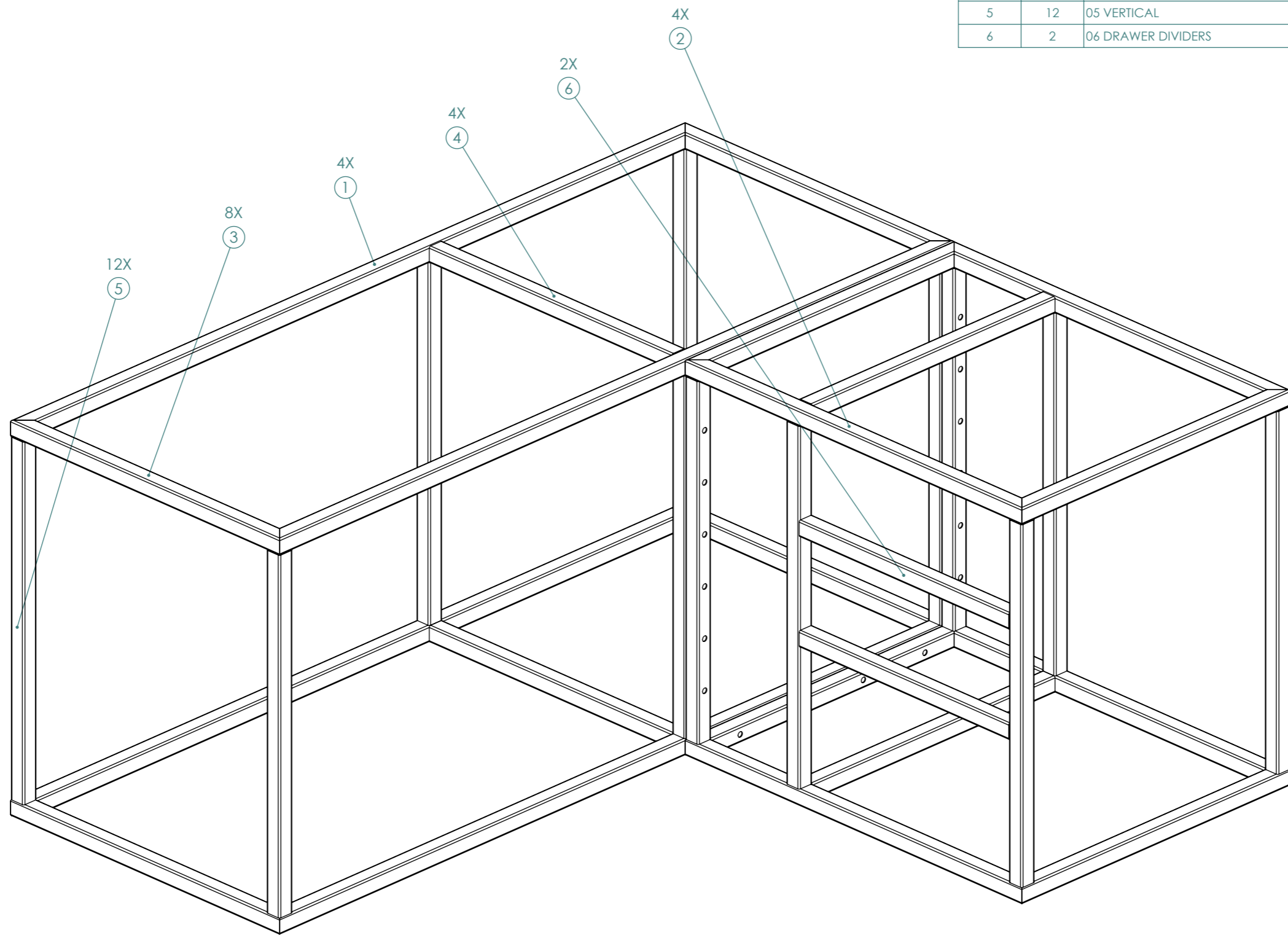

REV	DESCRIPTION	DATE	BY
-	INITIAL RELEASE	25/07/22	LF
-	APPROVAL RELEASE	25/07/22	LF

NAME	DATE
DRAWN LF	00/00/00
CHK'D AK	00/00/00
APPV'D MK	00/00/00

UNLESS OTHERWISE SPECIFIED
DIMENSIONS ARE IN MILLIMETERS
TOLERANCES:
LINEAR: ±1mm
ANGULAR: ±1°
REMOVE ALL SHARP EDGES & BURRS

MATERIAL: AS SHOWN
FINISH: AS SHOWN

DO NOT SCALE DRAWING



Rowlands Metal Works
QUALITY CRAFTSMANSHIP
SINCE 1956

Unit 13/19 Heath St.
Lonsdale SA 5160
p +61 (08) 8329 6700
f +61 (08) 8329 6701
metal@rowlandsmetal.com.au
www.rowlandsmetal.com.au
ABN 33 674 549 964

CUSTOMER: XXXXXX XXXX XXXXXX	REV: -	A3
PROJECT: OPV KITCHEN GALLEY	SHEET 4 OF 23	
DRAWING: XXXXX-OPV-SHIP5-3-235-A	FRAME CUTLIST	

FOR PRODUCTION

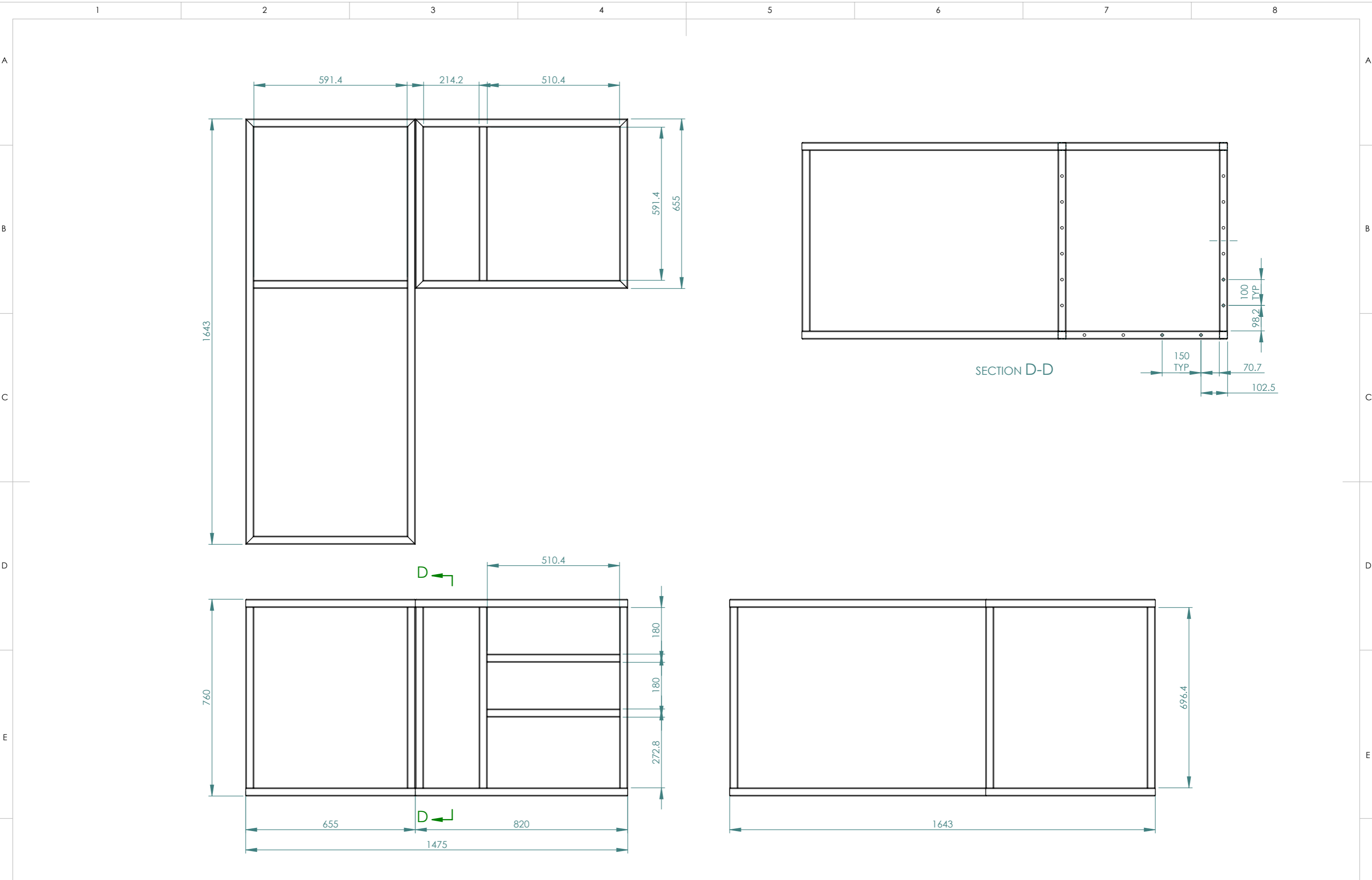

REV	DESCRIPTION	DATE	BY
C			
B			
A			
-	INITIAL RELEASE	25/07/22	LF
-	APPROVAL RELEASE	25/07/22	LF

NAME	DATE
DRAWN LF	00/00/00
CHK'D AK	00/00/00
APPV'D MK	00/00/00

UNLESS OTHERWISE SPECIFIED
DIMENSIONS ARE IN MILLIMETERS
TOLERANCES:
LINEAR: ±1mm
ANGULAR: ±1°
REMOVE ALL SHARP EDGES & BURRS

MATERIAL: AS SHOWN
FINISH: AS SHOWN

DO NOT SCALE DRAWING



Rowlands Metal Works
QUALITY CRAFTSMANSHIP
SINCE 1956

Unit 13/19 Heath St.
Lonsdale SA 5160
p +61 (08) 8329 6700
F +61 (08) 8329 6701
metal@rowlandsmetal.com.au
www.rowlandsmetal.com.au
ABN 33 674 549 964

CUSTOMER: XXXXXX XXXX XXXXXX	REV: -	A3
PROJECT: OPV KITCHEN GALLEY	SHEET 5 OF 23	
DRAWING: XXXXX-OPV-SHIP5-3-235-A		
SHEET NAME: FRAME DIMS		

PLEASE MEASURE THE FOLLOWING
DIMENSIONS FOR FITTED PARTS
NOMINAL DIMENSIONS SHOWN
MARK BELOW EACH LINE
ROUND TO THE NEAREST 0.5MM

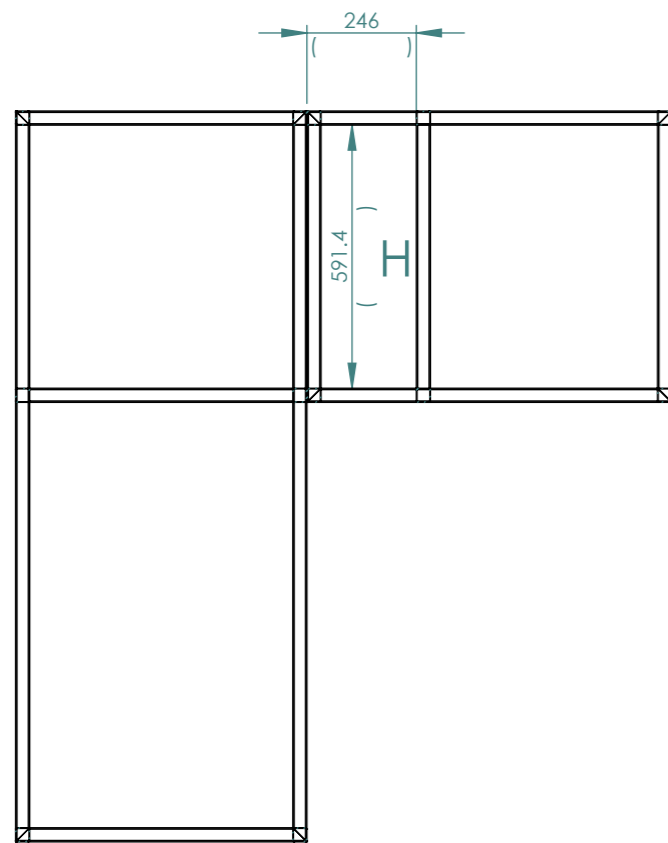

SECTION H-H

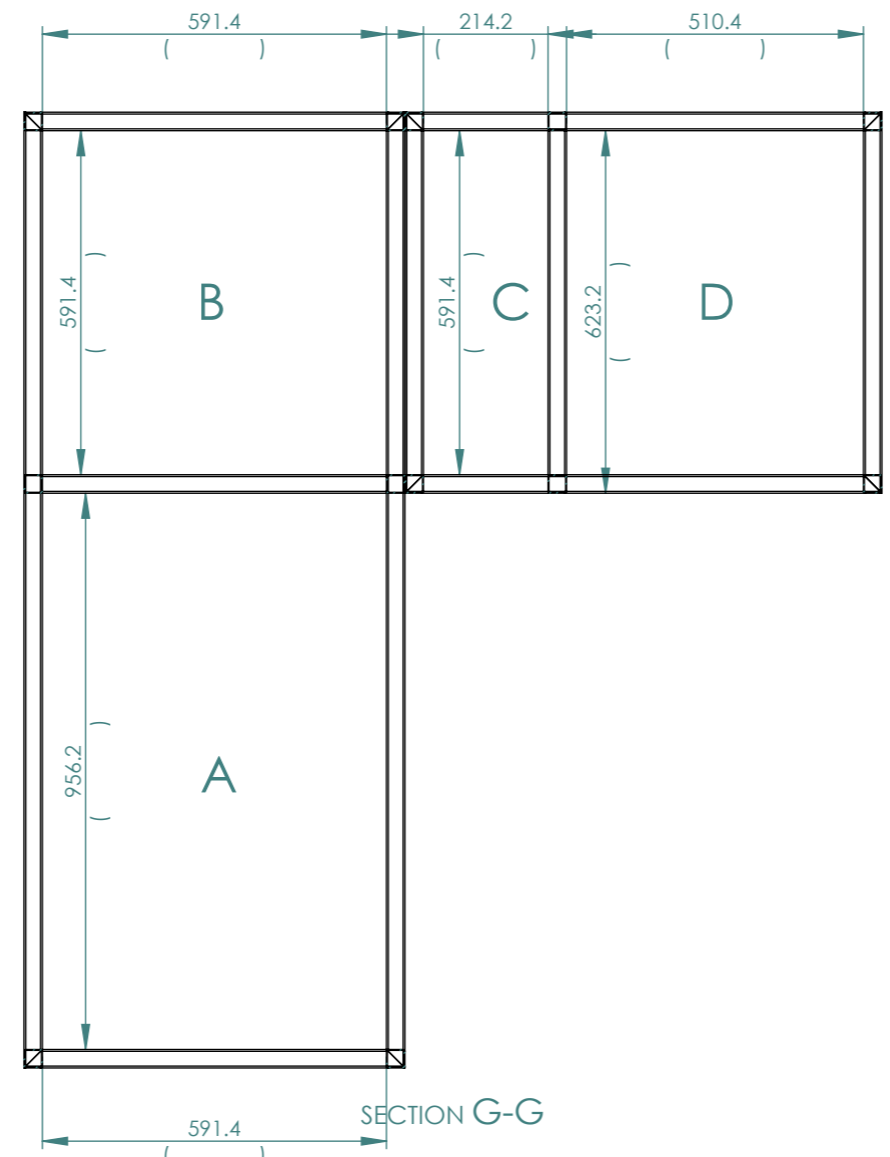

SECTION G-G

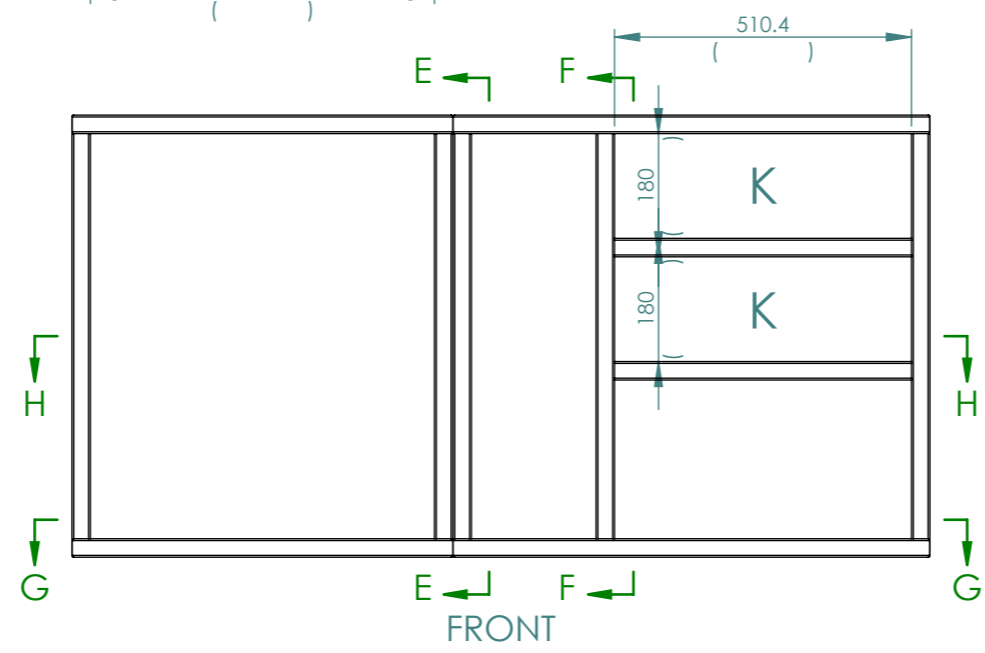

FRONT

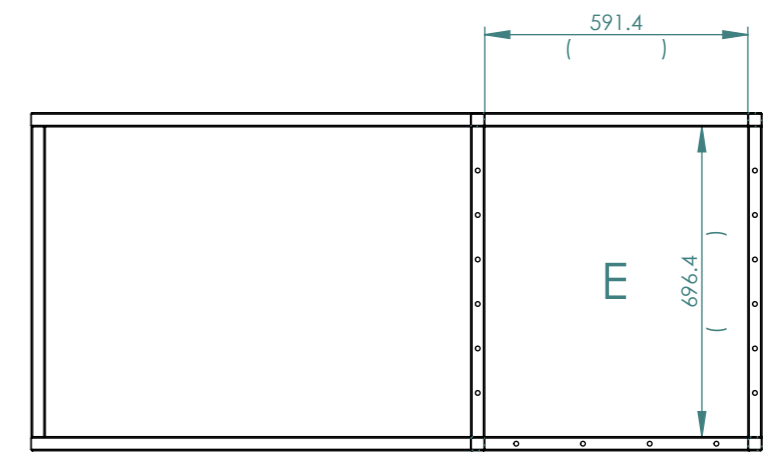

SECTION E-E

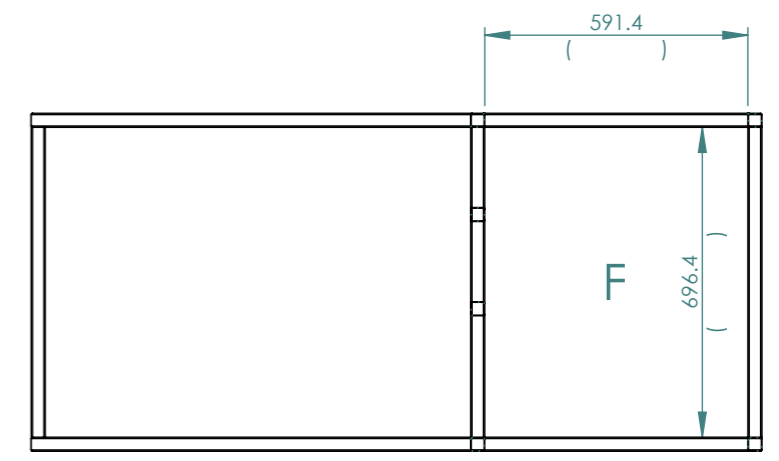

SECTION F-F

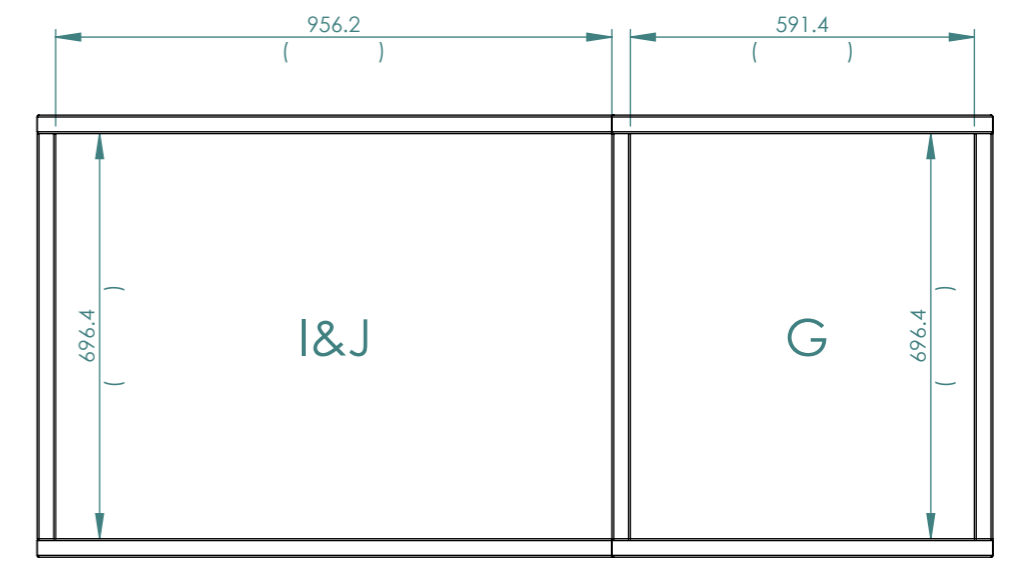

REV	DESCRIPTION	DATE	BY
C			
B			
A			
-	INITIAL RELEASE	25/07/22	LF
-	APPROVAL RELEASE	25/07/22	LF

NAME	DATE
DRAWN LF	00/00/00
CHK'D AK	00/00/00
APPV'D MK	00/00/00

UNLESS OTHERWISE SPECIFIED
DIMENSIONS ARE IN MILLIMETERS
TOLERANCES:
LINEAR: ±1mm
ANGULAR: ±1°
REMOVE ALL SHARP EDGES & BURRS

MATERIAL: AS SHOWN
FINISH: AS SHOWN

DO NOT SCALE DRAWING



Rowlands Metal Works
QUALITY CRAFTSMANSHIP SINCE 1956
Unit 13/19 Heath St.
Lonsdale SA 5160
p +61 (08) 8329 6700
f +61 (08) 8329 6701
metal@rowlandsmetal.com.au
www.rowlandsmetal.com.au
ABN 33 674 549 964

CUSTOMER: XXXXXX XXXX XXXXXX	REV: -	A3
PROJECT: OPV KITCHEN GALLEY	SHEET 6 OF 23	
DRAWING: XXXXX-OPV-SHIP5-3-235-A		
SHEET NAME: FRAME FITTING		

CUT LIST (XXXXX-OPV-SHIP5-3-235-A-SHEET)

ITEM	QTY	DESCRIPTION	TH	MATERIAL	BENDS
1	1	01 COUNTER TOP LEFT	1.6	304 S/S - #4 GRAIN	10
2	1	02 COUNTER TOP RIGHT	1.6	304 S/S - #4 GRAIN	10
3	2	03 COUNTER FILL CORNER	1.6	304 S/S - #4 GRAIN	2
4	1	04 COUNTER FILL LEFT	1.6	304 S/S - #4 GRAIN	2
5	1	05 COUNTER FILL RIGHT	1.6	304 S/S - #4 GRAIN	0
6	1	06 TOPHAT BRACE LONG	1.6	304 S/S - #4 GRAIN	4
7	1	07 TOPHAT BRACE MEDIUM	1.6	304 S/S - #4 GRAIN	4
8	1	08 TOPHAT BRACE SHORT	1.6	304 S/S - #4 GRAIN	4
9	2	09 SINK BOWL	1.6	304 S/S - #4 GRAIN	4
10	1	11 GALV BACKING LEFT	3	GALVANISED - RAW	0
11	1	12 GALV BACKING RIGHT	3	GALVANISED - RAW	0

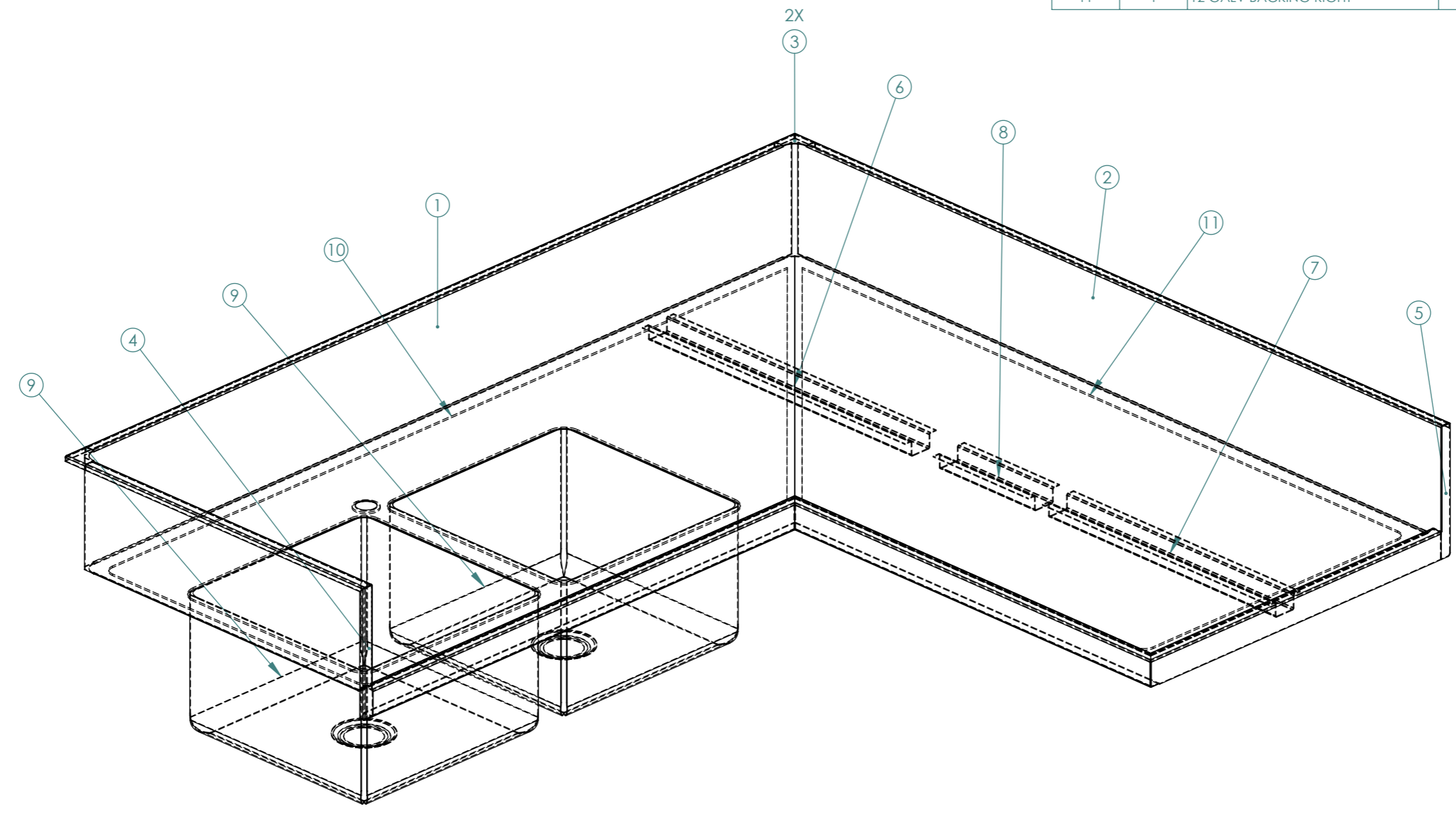

1	2	3	4	5	6	7	8	
A								A
B								B
C								C
D								D
E								E
F								F

C				NAME	DATE	UNLESS OTHERWISE SPECIFIED DIMENSIONS ARE IN MILLIMETERS TOLERANCES: LINEAR: ±1mm ANGULAR: ±1° REMOVE ALL SHARP EDGES & BURRS	
B			DRAWN	LF	00/00/00		
A			CHK'D	AK	00/00/00		
-	INITIAL RELEASE	25/07/22	LF	APPV'D	MK		
-	APPROVAL RELEASE	25/07/22	LF				
REV	DESCRIPTION	DATE	BY	FOR PRODUCTION		DO NOT SCALE DRAWING	

MATERIAL: AS SHOWN		FINISH: AS SHOWN		DO NOT SCALE DRAWING		Rowlands Metal Works QUALITY CRAFTSMANSHIP SINCE 1956	
		Unit 13/19 Heath St. Lonsdale SA 5160 p +61 (08) 8329 6700 f +61 (08) 8329 6701 metal@rowlandsmetal.com.au www.rowlandsmetal.com.au ABN 33 674 549 964		CUSTOMER: XXXXXX XXXX XXXXXX PROJECT: OPV KITCHEN GALLEY DRAWING: XXXXX-OPV-SHIP5-3-235-A SHEET NAME: SHEET CUTLIST		REV: -	A3
						SHEET 7 OF 23	

1 2 3 4 5 6 7 8

A B C D E F

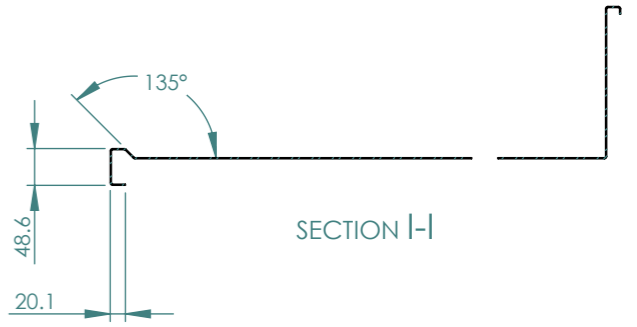
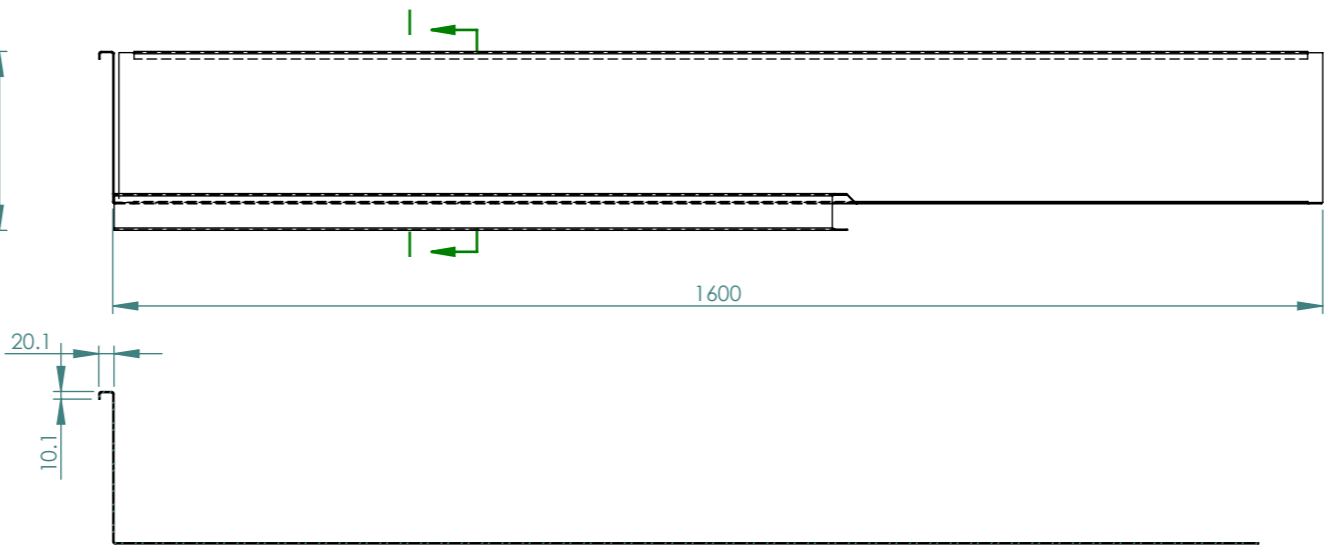
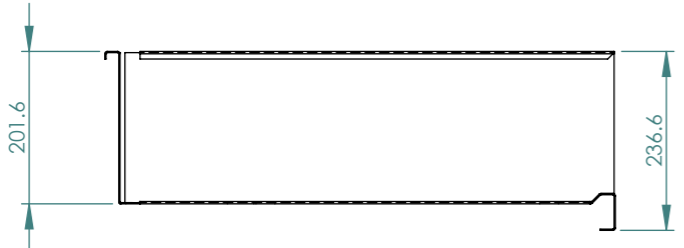
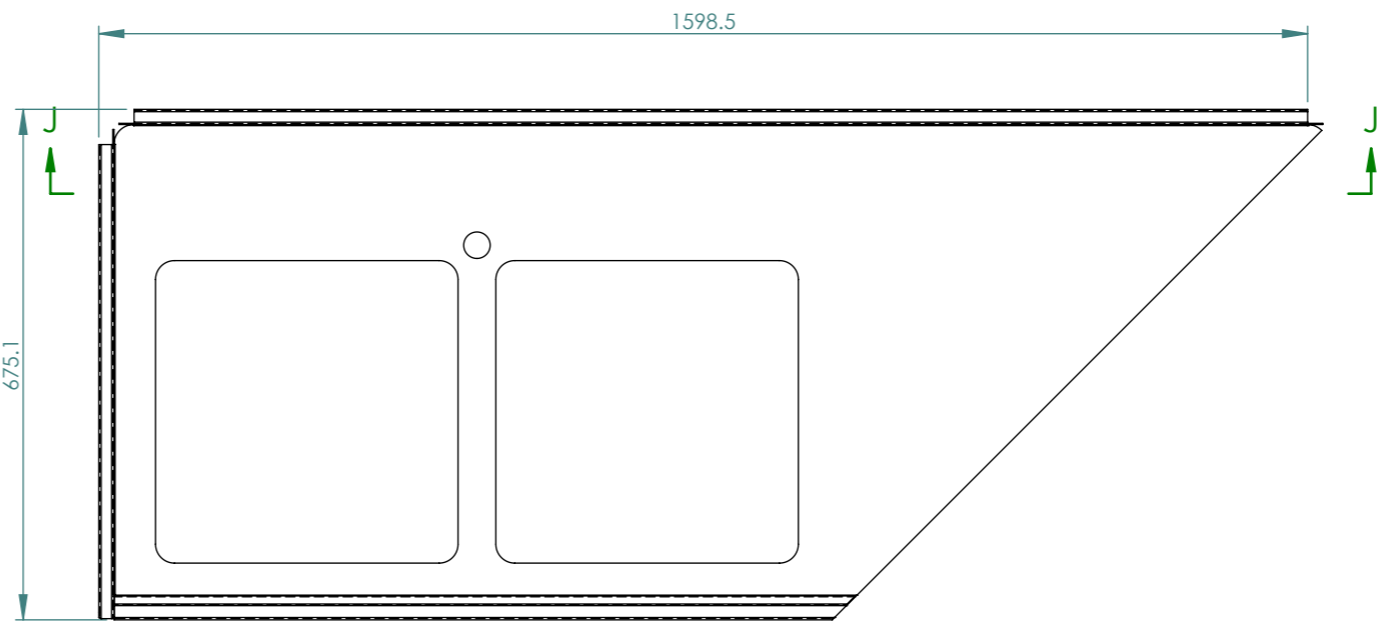
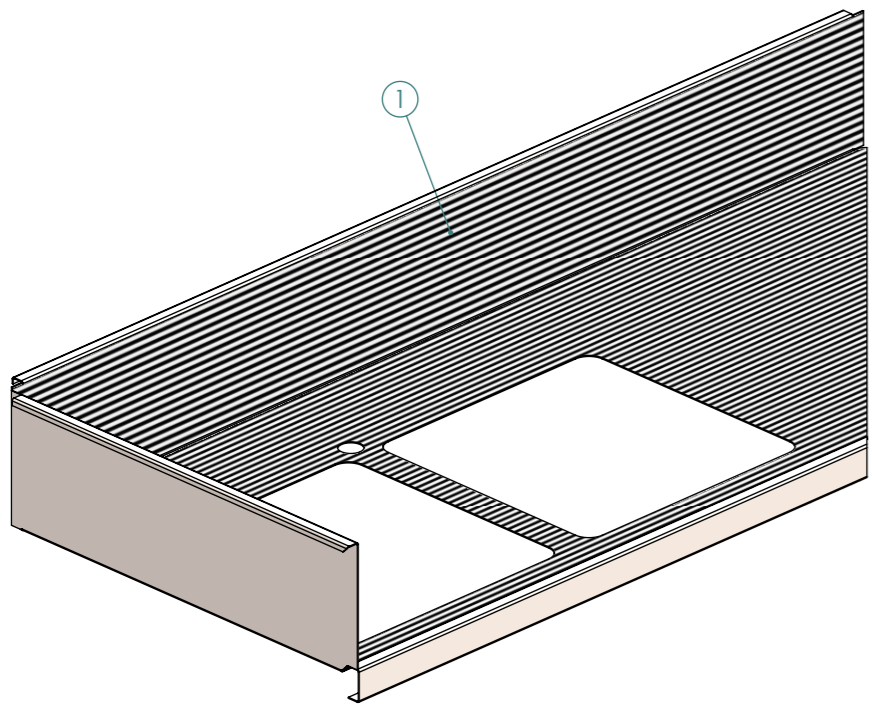

REV	DESCRIPTION	DATE	BY
C			
B			
A			
-	INITIAL RELEASE	25/07/22	LF
-	APPROVAL RELEASE	25/07/22	LF

UNLESS OTHERWISE SPECIFIED
DIMENSIONS ARE IN MILLIMETERS
TOLERANCES:
LINEAR: ±1mm
ANGULAR: ±1°
REMOVE ALL SHARP EDGES & BURRS

MATERIAL: AS SHOWN
FINISH: AS SHOWN
DO NOT SCALE DRAWING



**Rowlands
Metal Works**
QUALITY
CRAFTSMANSHIP
SINCE 1956

Unit 13/19 Heath St.
Lonsdale SA 5160
p +61 (08) 8329 6700
F +61 (08) 8329 6701
metal@rowlandsmetal.com.au
www.rowlandsmetal.com.au
ABN 33 674 549 964

CUSTOMER: XXXXXX XXXX XXXXXX	REV: -	A3
PROJECT: OPV KITCHEN GALLEY	SHEET 8 OF 23	
DRAWING: XXXXX-OPV-SHIP5-3-235-A	SHEET ITEMS 1	

FOR PRODUCTION

1 2 3 4 5 6 7 8

A

B

C

D

E

F

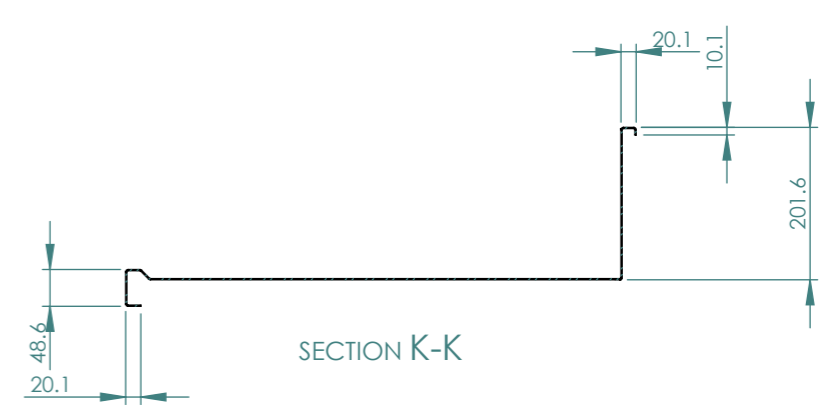
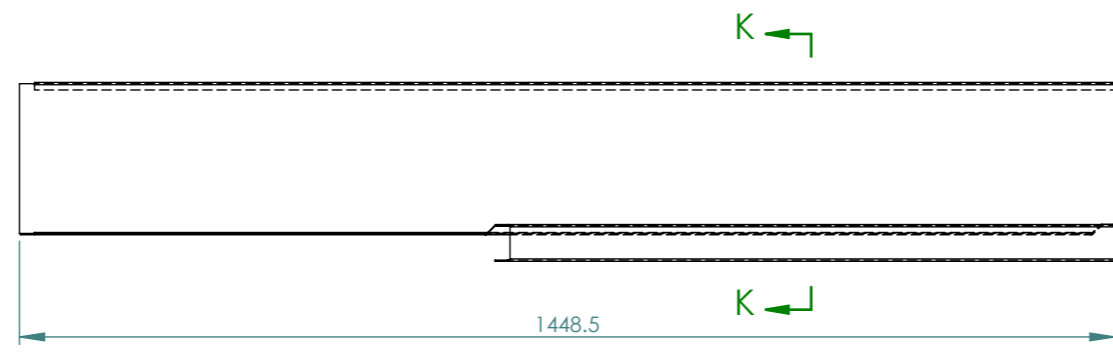
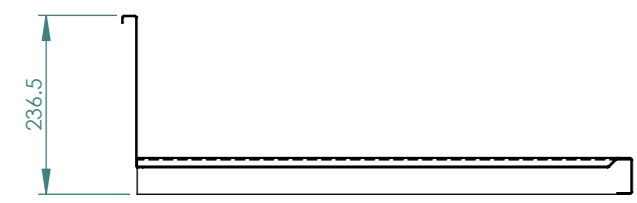
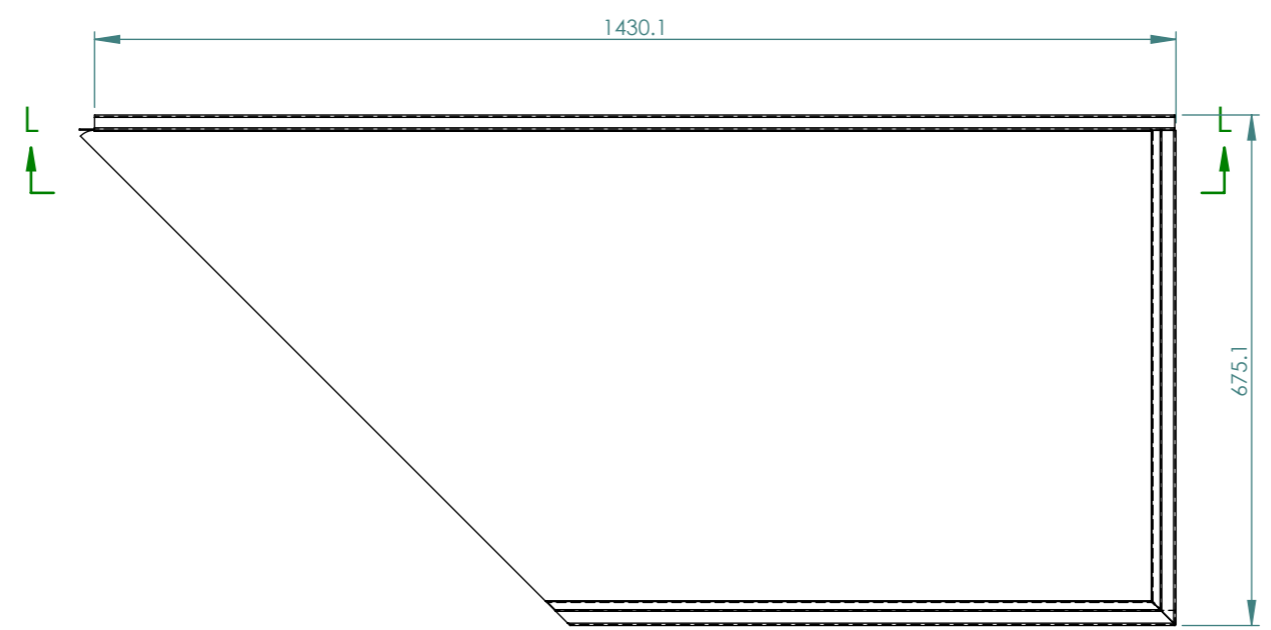
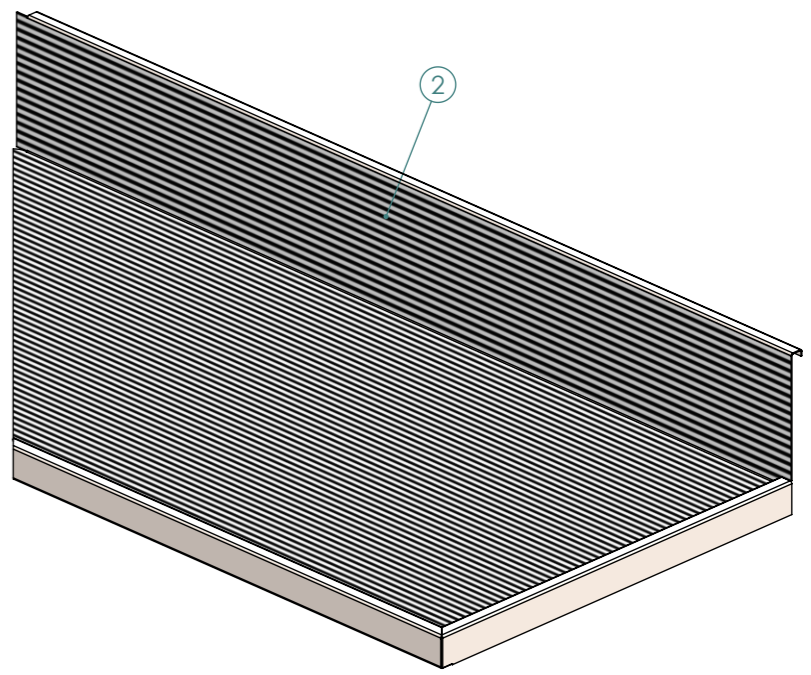

SECTION L-L

SECTION K-K

REV	DESCRIPTION	DATE	BY
C			
B			
A			
-	INITIAL RELEASE	25/07/22	LF
-	APPROVAL RELEASE	25/07/22	LF

UNLESS OTHERWISE SPECIFIED
DIMENSIONS ARE IN MILLIMETERS
TOLERANCES:
LINEAR: ±1mm
ANGULAR: ±1°
REMOVE ALL SHARP EDGES & BURRS

MATERIAL: AS SHOWN
FINISH: AS SHOWN
DO NOT SCALE DRAWING



**Rowlands
Metal Works**
QUALITY
CRAFTSMANSHIP
SINCE 1956

Unit 13/19 Heath St.
Lonsdale SA 5160
p +61 (08) 8329 6700
F +61 (08) 8329 6701
metal@rowlandsmetal.com.au
www.rowlandsmetal.com.au
ABN 33 674 549 964

CUSTOMER: XXXXXX XXXX XXXXXX	REV: -	A3
PROJECT: OPV KITCHEN GALLEY		
DRAWING: XXXXX-OPV-SHIP5-3-235-A		
SHEET NAME: SHEET ITEMS 2	SHEET 9 OF 23	

FOR PRODUCTION



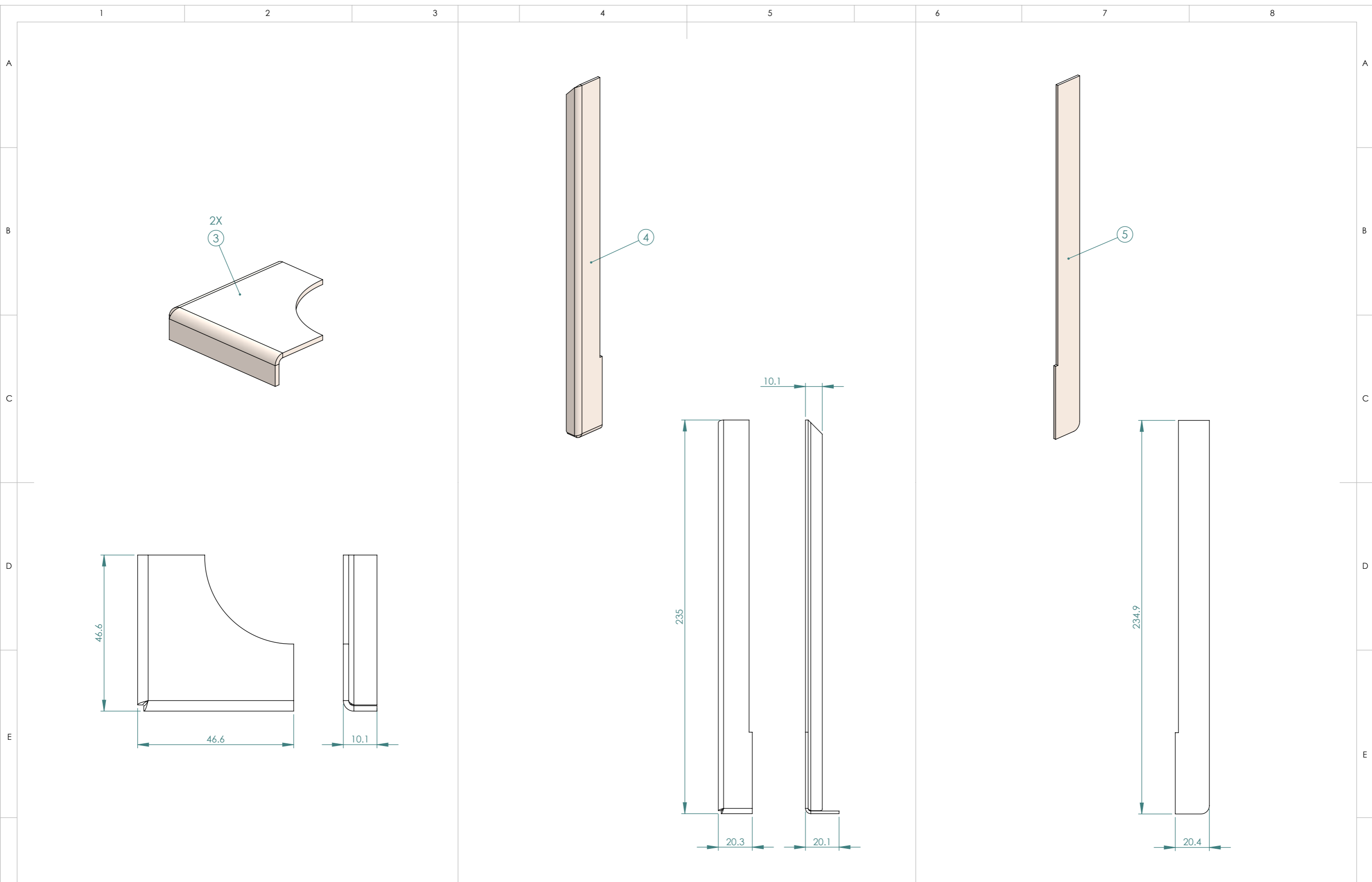

REV	DESCRIPTION	DATE	BY
C			
B			
A			
-	INITIAL RELEASE	25/07/22	LF
-	APPROVAL RELEASE	25/07/22	LF

UNLESS OTHERWISE SPECIFIED
DIMENSIONS ARE IN MILLIMETERS
TOLERANCES:
LINEAR: ±1mm
ANGULAR: ±1°
REMOVE ALL SHARP EDGES & BURRS

MATERIAL: AS SHOWN
FINISH: AS SHOWN
DO NOT SCALE DRAWING



**Rowlands
Metal Works**
QUALITY CRAFTSMANSHIP
SINCE 1956

Unit 13/19 Heath St.
Lonsdale SA 5160
p +61 (08) 8329 6700
F +61 (08) 8329 6701
metal@rowlandsmetal.com.au
www.rowlandsmetal.com.au
ABN 33 674 549 964

CUSTOMER: XXXXXX XXXX XXXXXX	REV: -	A3
PROJECT: OPV KITCHEN GALLEY	SHEET 10 OF 23	
DRAWING: XXXXX-OPV-SHIP5-3-235-A		
SHEET NAME: SHEET ITEMS 3		

FOR PRODUCTION

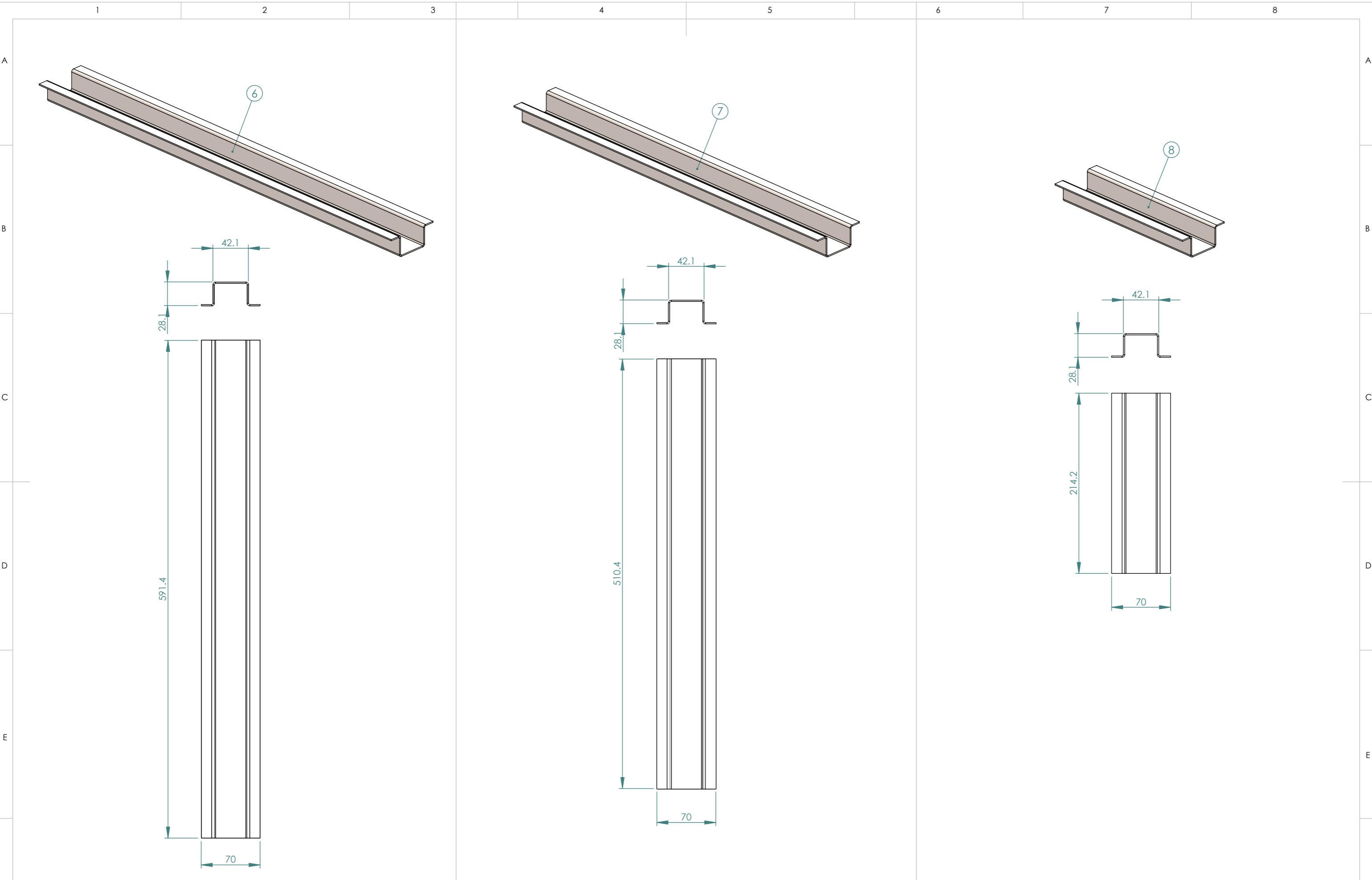

REV	DESCRIPTION	DATE	BY
C			
B			
A			
-	INITIAL RELEASE	25/07/22	LF
-	APPROVAL RELEASE	25/07/22	LF

UNLESS OTHERWISE SPECIFIED
DIMENSIONS ARE IN MILLIMETERS
TOLERANCES:
LINEAR: ±1mm
ANGULAR: ±1°
REMOVE ALL SHARP EDGES & BURRS

MATERIAL: AS SHOWN
FINISH: AS SHOWN
DO NOT SCALE DRAWING

FOR PRODUCTION



**Rowlands
Metal Works**
QUALITY
CRAFTSMANSHIP
SINCE 1956

Unit 13/19 Heath St.
Lonsdale SA 5160
p +61 (08) 8329 6700
F +61 (08) 8329 6701
metal@rowlandsmetal.com.au
www.rowlandsmetal.com.au
ABN 33 674 549 964

CUSTOMER: XXXXXX XXXX XXXXXX	REV: -	A3
PROJECT: OPV KITCHEN GALLEY	SHEET 11 OF 23	
DRAWING: XXXXX-OPV-SHIP5-3-235-A	SHEET NAME: SHEET ITEMS 4	

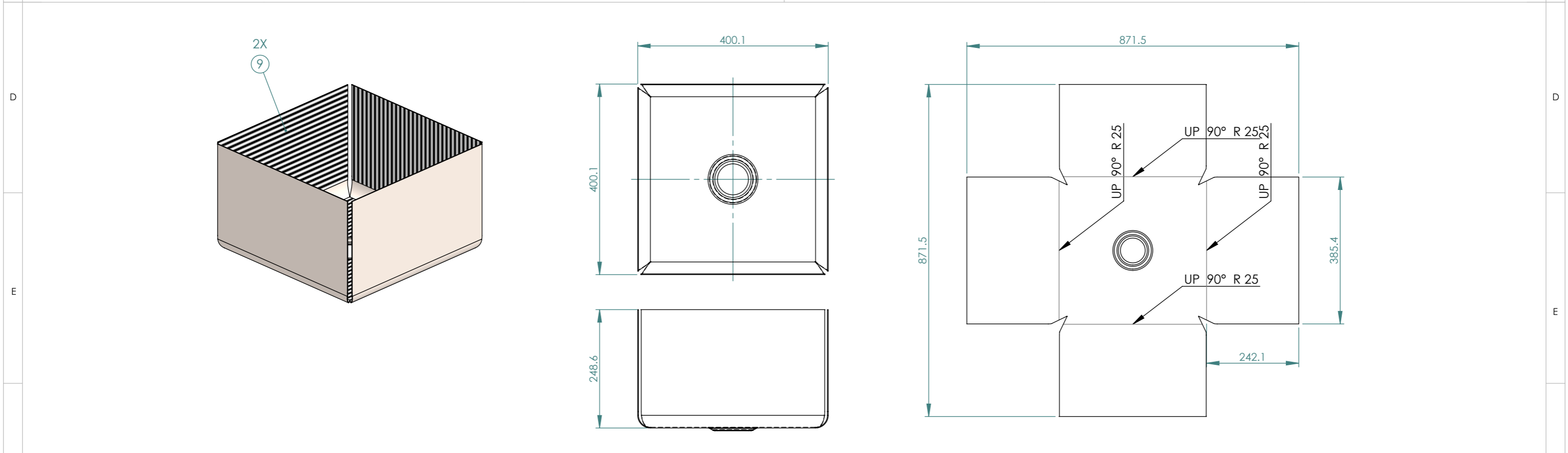
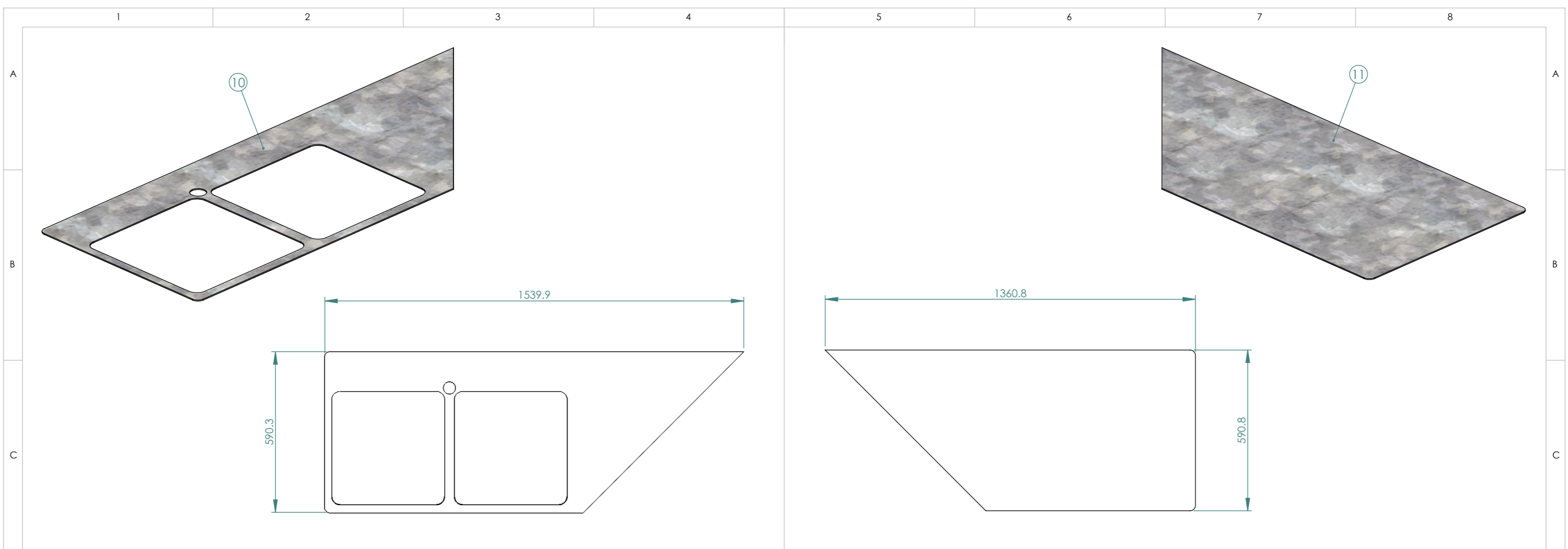

C				NAME	DATE	UNLESS OTHERWISE SPECIFIED DIMENSIONS ARE IN MILLIMETERS TOLERANCES: LINEAR: ±1mm ANGULAR: ±1° REMOVE ALL SHARP EDGES & BURRS	MATERIAL:	AS SHOWN	Rowlands Metal Works QUALITY CRAFTSMANSHIP SINCE 1956	Unit 13/19 Heath St. Lonsdale SA 5160 p +61 (08) 8329 6700 F +61 (08) 8329 6701 metal@rowlandsmetal.com.au www.rowlandsmetal.com.au ABN 33 674 549 964	CUSTOMER:	XXXXXX XXXX XXXXXX	REV: - A3 SHEET 12 OF 23
B			DRAWN	LF	00/00/00		FINISH:	AS SHOWN		PROJECT:	OPV KITCHEN GALLEY		
A			CHK'D	AK	00/00/00					DRAWING:	XXXXX-OPV-SHIP5-3-235-A		
-	INITIAL RELEASE	25/07/22	LF	APPV'D	MK		00/00/00				SHEET NAME:	SHEET ITEMS 5	
-	APPROVAL RELEASE	25/07/22	LF										
REV	DESCRIPTION	DATE	BY	FOR PRODUCTION			DO NOT SCALE DRAWING						

CUT LIST (A PANEL HORIZ (235))

ITEM	QTY	DESCRIPTION	TH	MATERIAL	BENDS
1	1	A1 PANEL HORIZ	1.6	304 S/S - #4 GRAIN	4

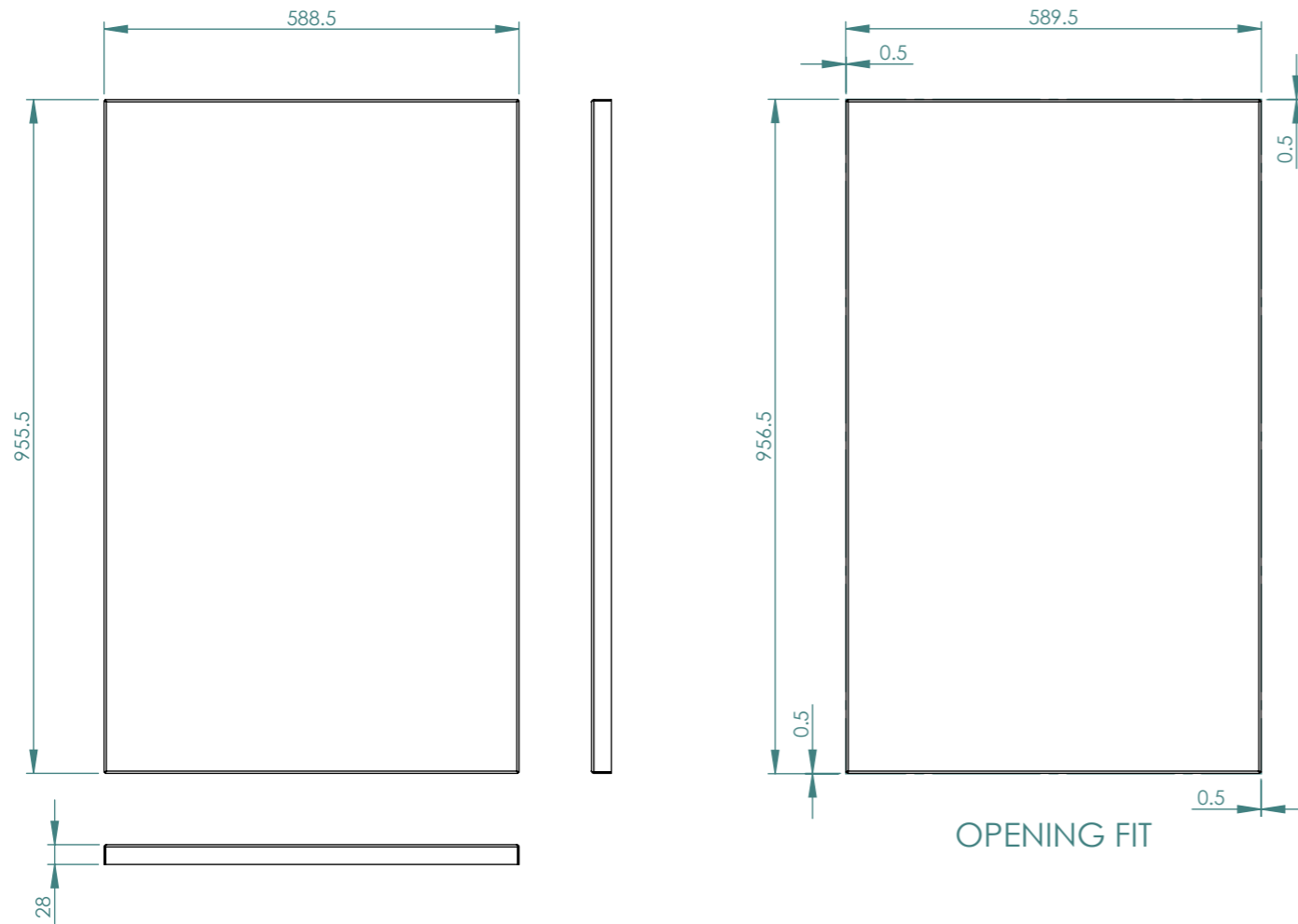
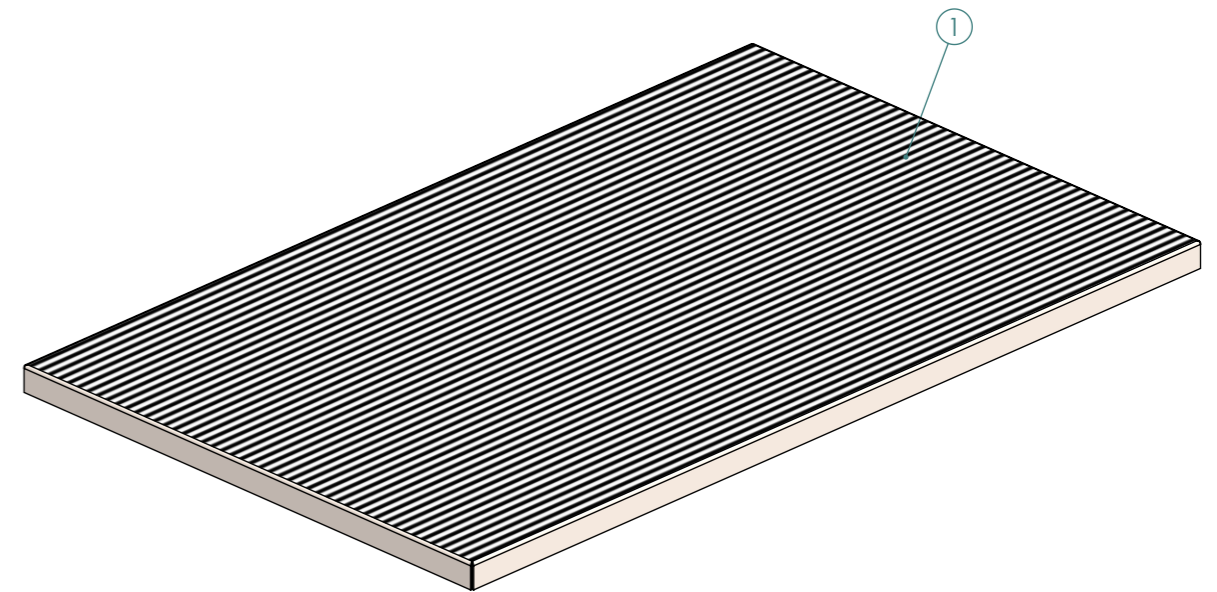
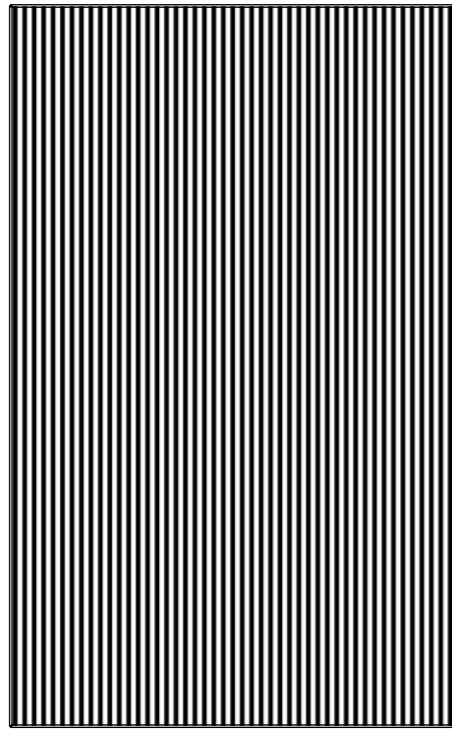

OPENING FIT

REV	DESCRIPTION	DATE	BY
C			
B			
A			
-	INITIAL RELEASE	25/07/22	LF
-	APPROVAL RELEASE	25/07/22	LF

FOR PRODUCTION



MATERIAL:	AS SHOWN
FINISH:	AS SHOWN
DO NOT SCALE DRAWING	



Rowlands Metal Works
 QUALITY CRAFTSMANSHIP
 SINCE 1958

Unit 13/19 Heath St.
 Lonsdale SA 5160
 p +61 (08) 8329 6700
 f +61 (08) 8329 6701
 metal@rowlandsmetal.com.au
 www.rowlandsmetal.com.au
 ABN 33 674 549 964

CUSTOMER:	XXXXXX XXXX XXXXXX
PROJECT:	OPV KITCHEN GALLEY
DRAWING:	XXXXX-OPV-SHIP5-3-235-A
SHEET NAME:	A PANEL HORIZ
REV:	-
A3	
SHEET 13 OF 23	

CUT LIST (B PANEL HORIZ (235))

ITEM	QTY	DESCRIPTION	TH	MATERIAL	BENDS
1	1	B1 PANEL HORIZ	1.6	304 S/S - #4 GRAIN	4

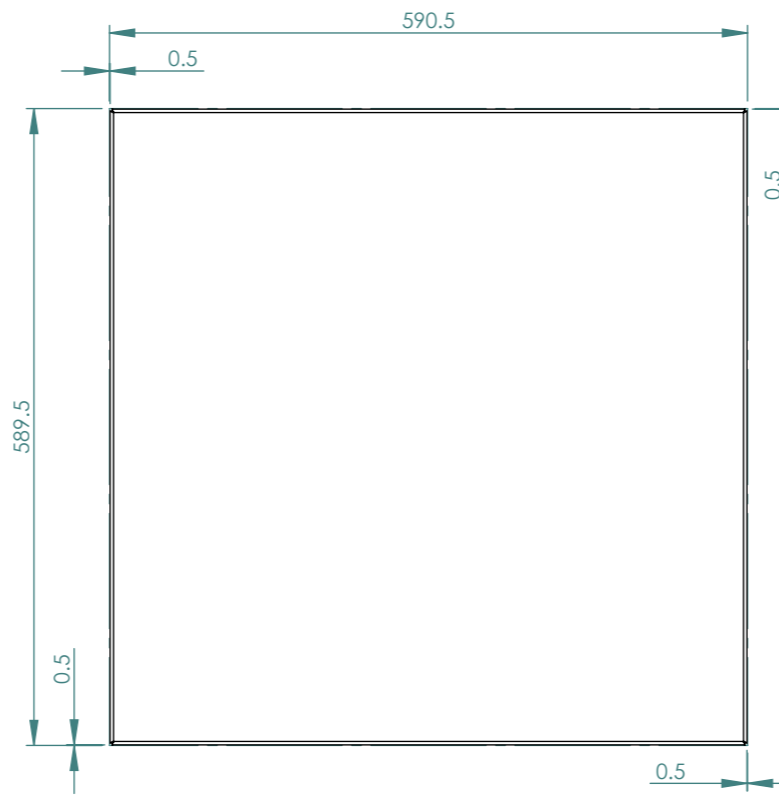
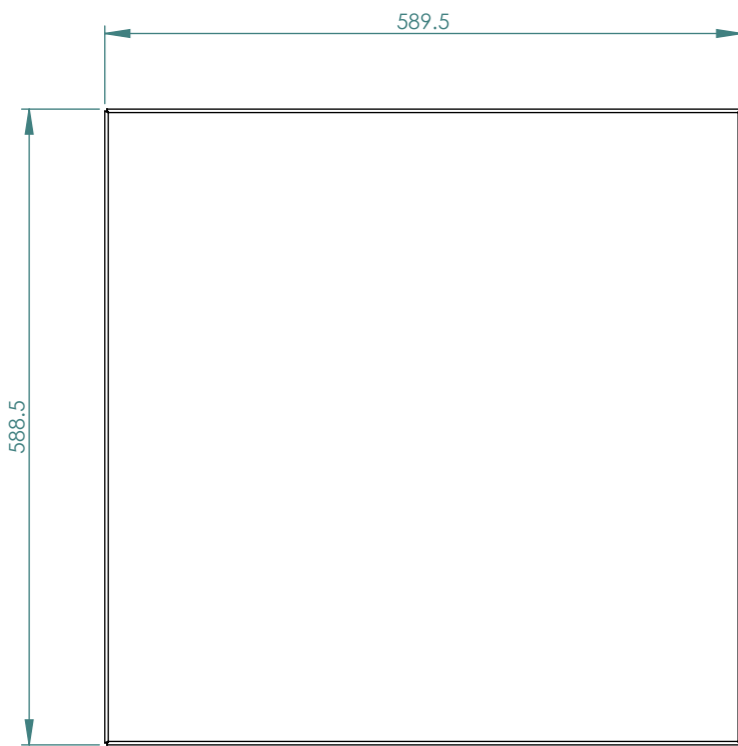
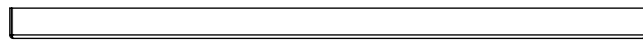
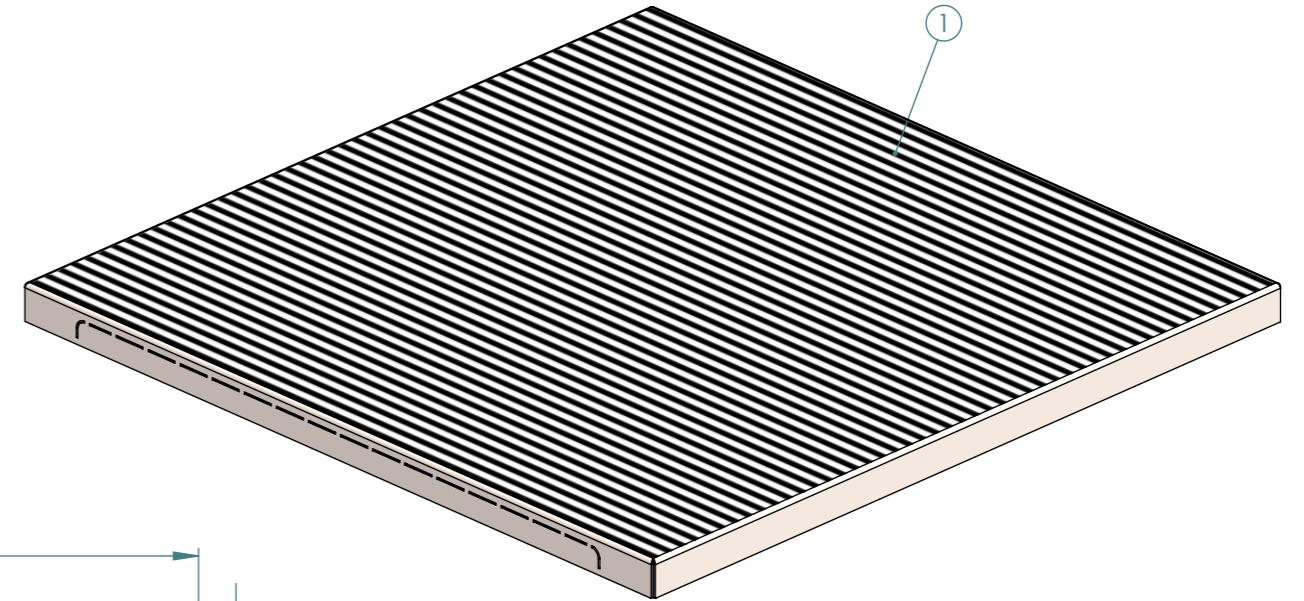
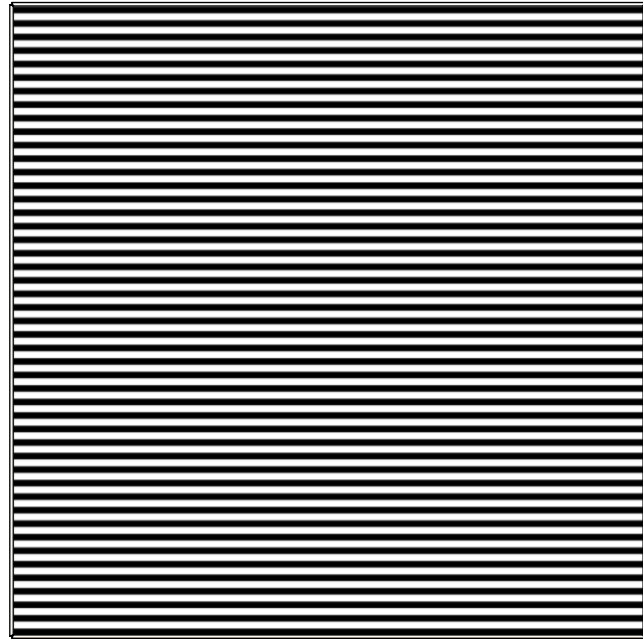

OPENING FIT

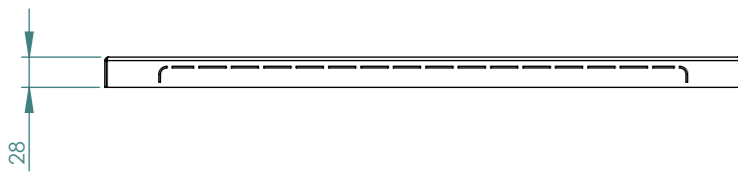

REV	DESCRIPTION	DATE	BY
C			
B			
A			
-	INITIAL RELEASE	25/07/22	LF
-	APPROVAL RELEASE	25/07/22	LF

NAME	DATE
DRAWN LF	00/00/00
CHK'D AK	00/00/00
APPV'D MK	00/00/00

UNLESS OTHERWISE SPECIFIED
DIMENSIONS ARE IN MILLIMETERS
TOLERANCES:
LINEAR: ±1mm
ANGULAR: ±1°
REMOVE ALL SHARP EDGES & BURRS

MATERIAL: AS SHOWN
FINISH: AS SHOWN

DO NOT SCALE DRAWING



Rowlands Metal Works
QUALITY CRAFTSMANSHIP SINCE 1956
Unit 13/19 Heath St.
Lonsdale SA 5160
p +61 (08) 8329 6700
F +61 (08) 8329 6701
metal@rowlandsmetal.com.au
www.rowlandsmetal.com.au
ABN 33 674 549 964

CUSTOMER: XXXXXX XXXX XXXXXX	REV: -	A3
PROJECT: OPV KITCHEN GALLEY	SHEET 14 OF 23	
DRAWING: XXXXX-OPV-SHIP5-3-235-A		
SHEET NAME: B PANEL HORIZ		

CUT LIST (C PANEL HORIZ (235))

ITEM	QTY	DESCRIPTION	TH	MATERIAL	BENDS
1	1	C1 PANEL HORIZ	1.6	304 S/S - #4 GRAIN	4

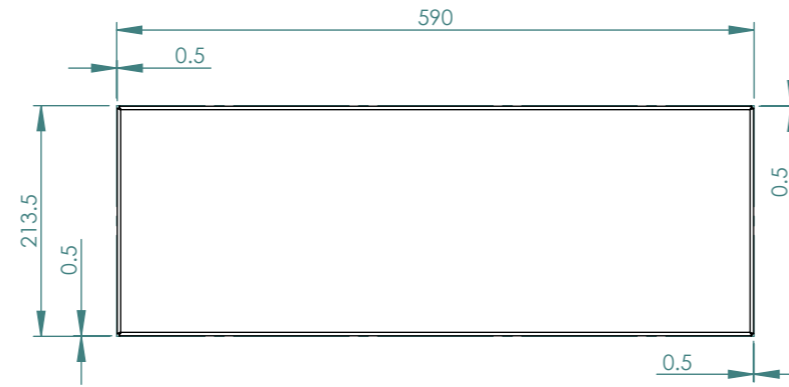
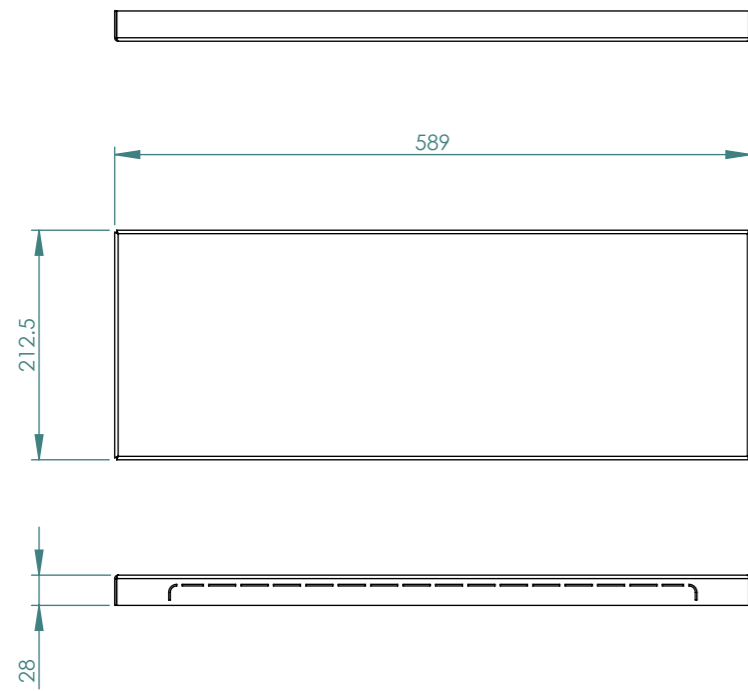
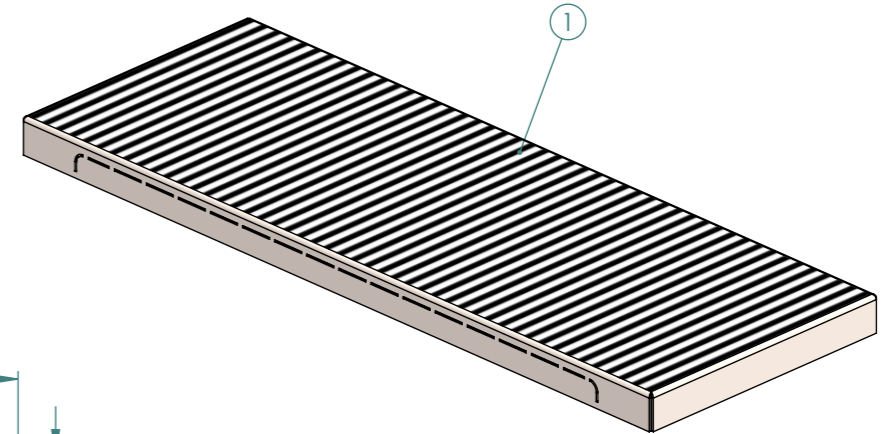
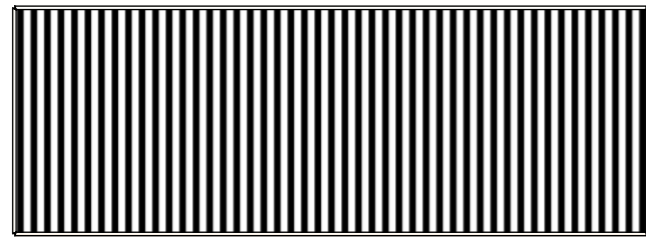

OPENING FIT

REV	DESCRIPTION	DATE	BY
C			
B			
A			
-	INITIAL RELEASE	25/07/22	LF
-	APPROVAL RELEASE	25/07/22	LF

UNLESS OTHERWISE SPECIFIED
DIMENSIONS ARE IN MILLIMETERS
TOLERANCES:
LINEAR: ±1mm
ANGULAR: ±1°
REMOVE ALL SHARP EDGES & BURRS

MATERIAL: AS SHOWN
FINISH: AS SHOWN
DO NOT SCALE DRAWING



**Rowlands
Metal Works**
QUALITY CRAFTSMANSHIP
SINCE 1956

Unit 13/19 Heath St.
Lonsdale SA 5160
p +61 (08) 8329 6700
f +61 (08) 8329 6701
metal@rowlandsmetal.com.au
www.rowlandsmetal.com.au
ABN 33 674 549 964

CUSTOMER: XXXXXX XXXX XXXXXX	REV: -	A3
PROJECT: OPV KITCHEN GALLEY	SHEET 15 OF 23	
DRAWING: XXXXX-OPV-SHIP5-3-235-A		
SHEET NAME: C PANEL HORIZ		

CUT LIST (D PANEL SHELF HORIZ (235))					
ITEM	QTY	DESCRIPTION	TH	MATERIAL	BENDS
1	1	D1 SHELF	1.6	304 S/S - #4 GRAIN	7
2	1	D2 BAR	3	304 S/S - #4 GRAIN	0

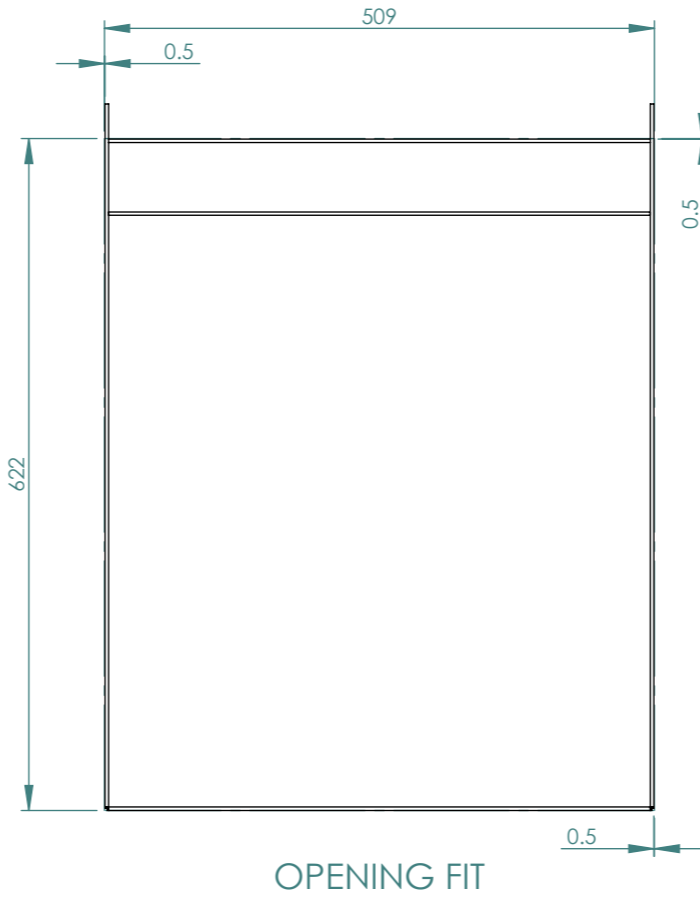
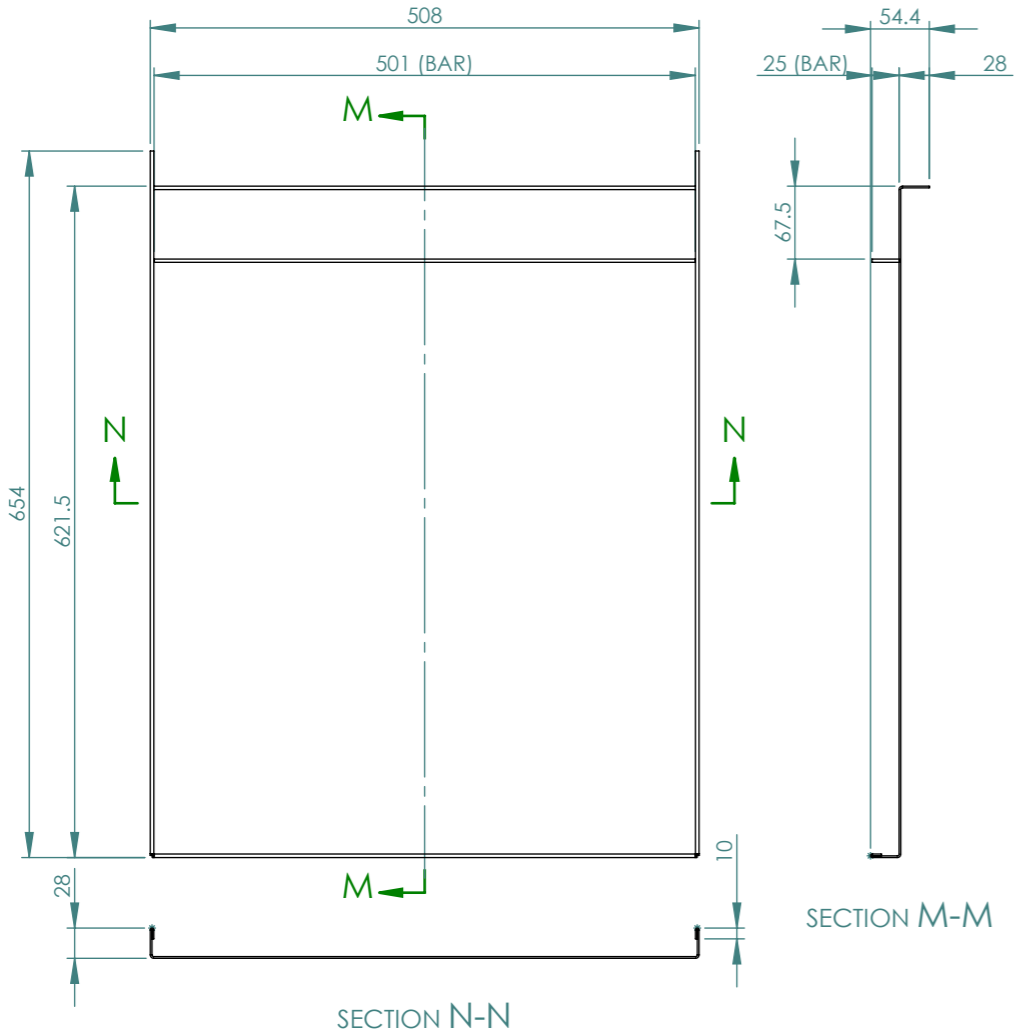
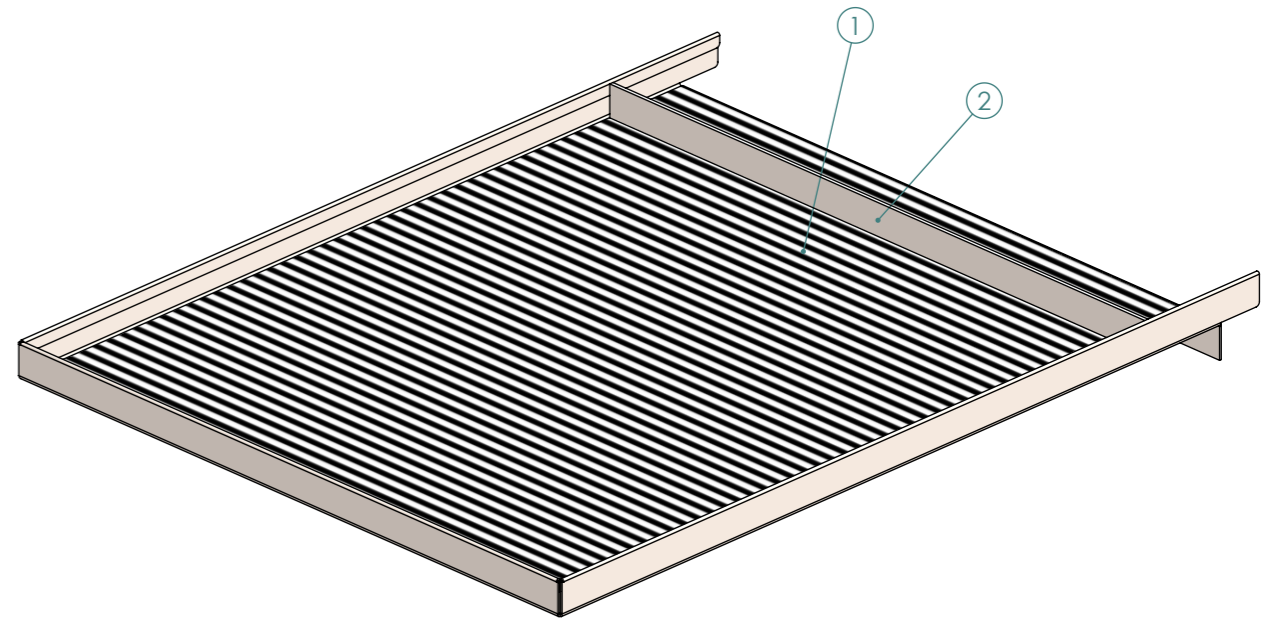
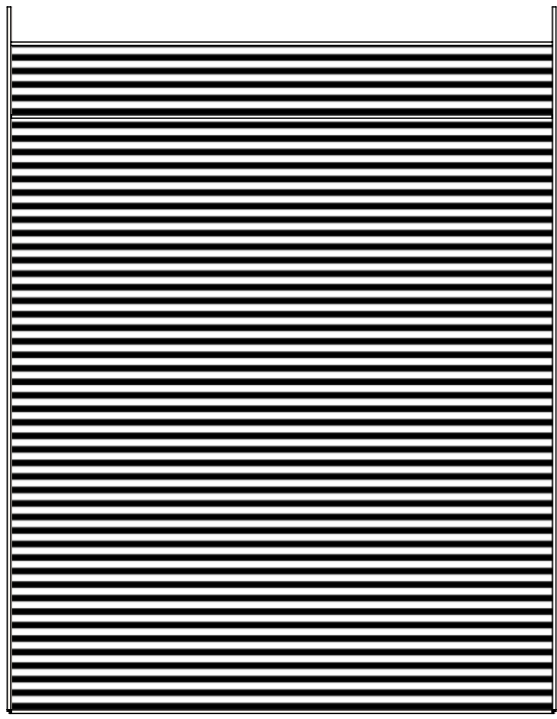

REV	DESCRIPTION	DATE	BY
C			
B			
A			
-	INITIAL RELEASE	25/07/22	LF
-	APPROVAL RELEASE	25/07/22	LF

NAME	DATE
DRAWN LF	00/00/00
CHK'D AK	00/00/00
APPV'D MK	00/00/00

UNLESS OTHERWISE SPECIFIED
DIMENSIONS ARE IN MILLIMETERS
TOLERANCES:
LINEAR: ±1mm
ANGULAR: ±1°
REMOVE ALL SHARP EDGES & BURRS

MATERIAL: AS SHOWN
FINISH: AS SHOWN

FOR PRODUCTION

DO NOT SCALE DRAWING

Rowlands Metal Works
QUALITY CRAFTSMANSHIP SINCE 1956

Unit 13/19 Heath St.
Lonsdale SA 5160
p +61 (08) 8329 6700
f +61 (08) 8329 6701
metal@rowlandsmetal.com.au
www.rowlandsmetal.com.au
ABN 33 674 549 964

CUSTOMER: XXXXXX XXXX XXXXXX	REV: -	A3
PROJECT: OPV KITCHEN GALLEY	SHEET 16 OF 23	
DRAWING: XXXXX-OPV-SHIP5-3-235-A		
SHEET NAME: D PANEL SHELF HORIZ		

CUT LIST (E PANEL VERT (235))

ITEM	QTY	DESCRIPTION	TH	MATERIAL	BENDS
1	1	E1 PANEL VERT	1.6	304 S/S - #4 GRAIN	4

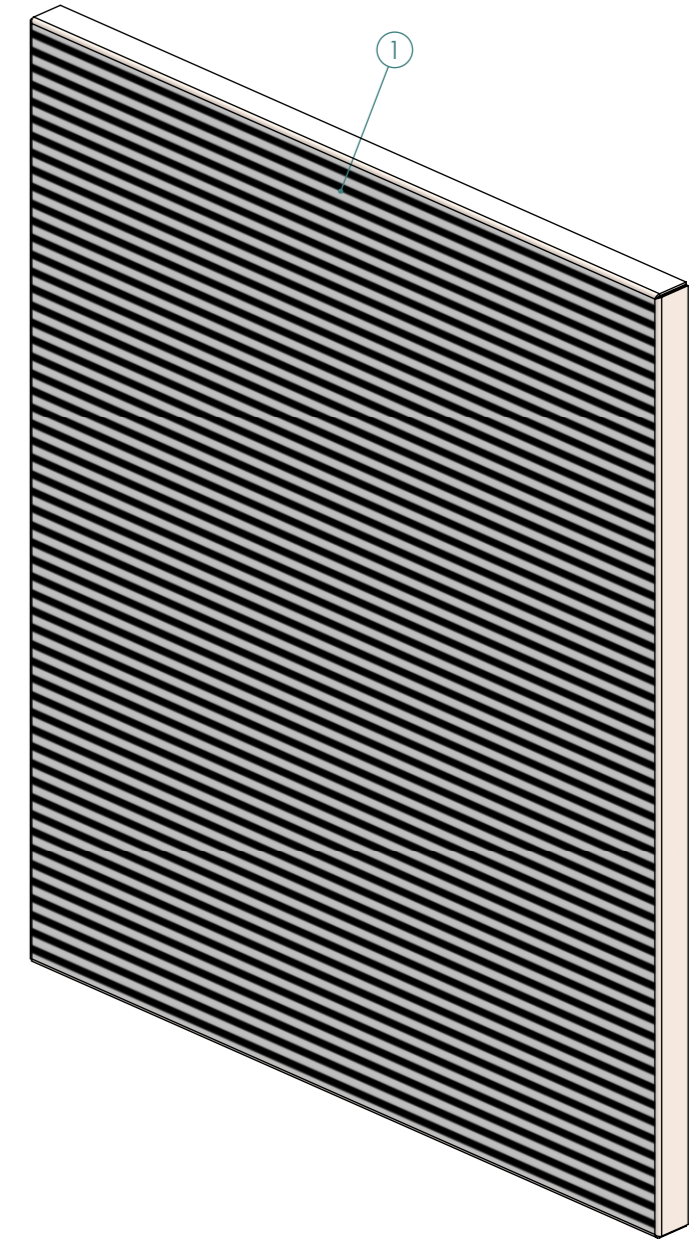
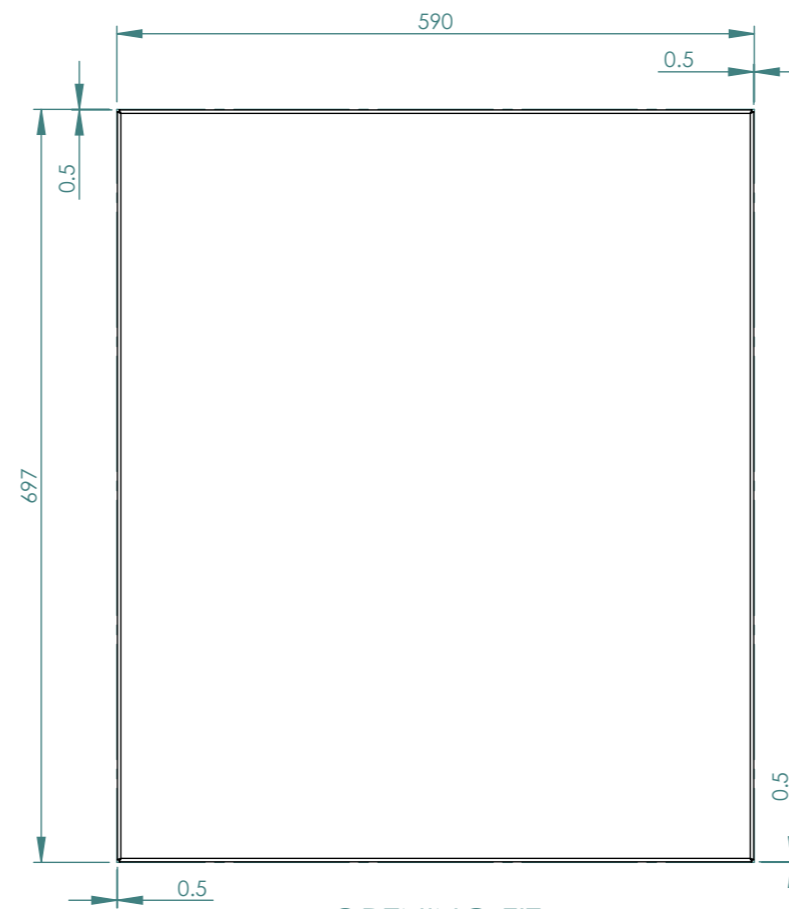
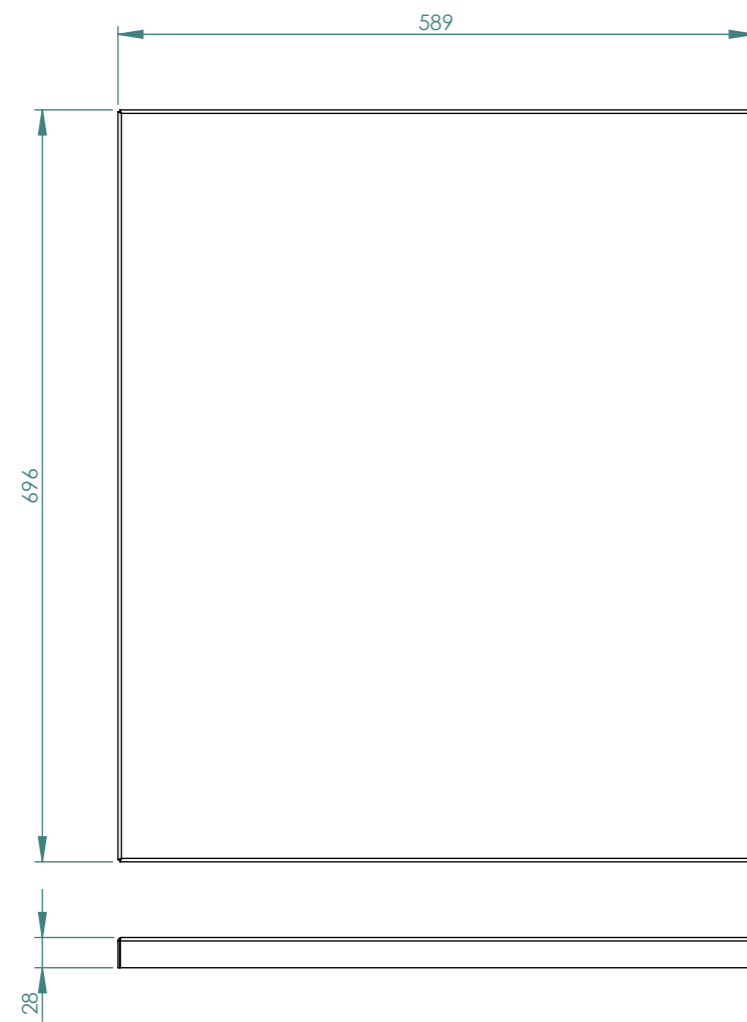
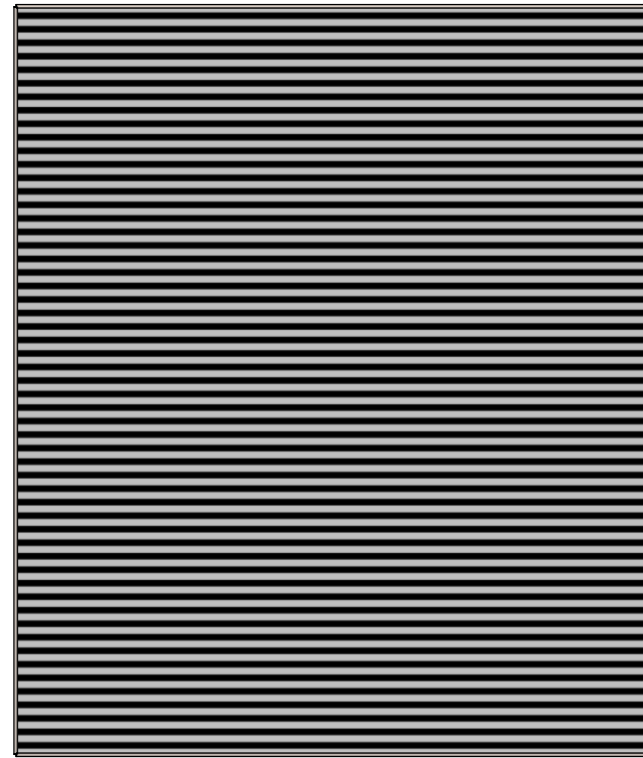

REV	DESCRIPTION	DATE	BY
C			
B			
A			
-	INITIAL RELEASE	25/07/22	LF
-	APPROVAL RELEASE	25/07/22	LF

UNLESS OTHERWISE SPECIFIED
DIMENSIONS ARE IN MILLIMETERS
TOLERANCES:
LINEAR: ±1mm
ANGULAR: ±1°
REMOVE ALL SHARP EDGES & BURRS

MATERIAL: AS SHOWN
FINISH: AS SHOWN
DO NOT SCALE DRAWING



Rowlands Metal Works
QUALITY CRAFTSMANSHIP SINCE 1956
Unit 13/19 Heath St.
Lonsdale SA 5160
p +61 (08) 8329 6700
F +61 (08) 8329 6701
metal@rowlandsmetal.com.au
www.rowlandsmetal.com.au
ABN 33 674 549 964

CUSTOMER: XXXXXX XXXX XXXXXX
PROJECT: OPV KITCHEN GALLEY
DRAWING: XXXXX-OPV-SHIP5-3-235-A
SHEET NAME: E PANEL VERT
REV: - A3
SHEET 17 OF 23

FOR PRODUCTION

CUT LIST (F PANEL VERT (235))

ITEM	QTY	DESCRIPTION	TH	MATERIAL	BENDS
1	1	F1 PANEL VERT	1.6	304 S/S - #4 GRAIN	4

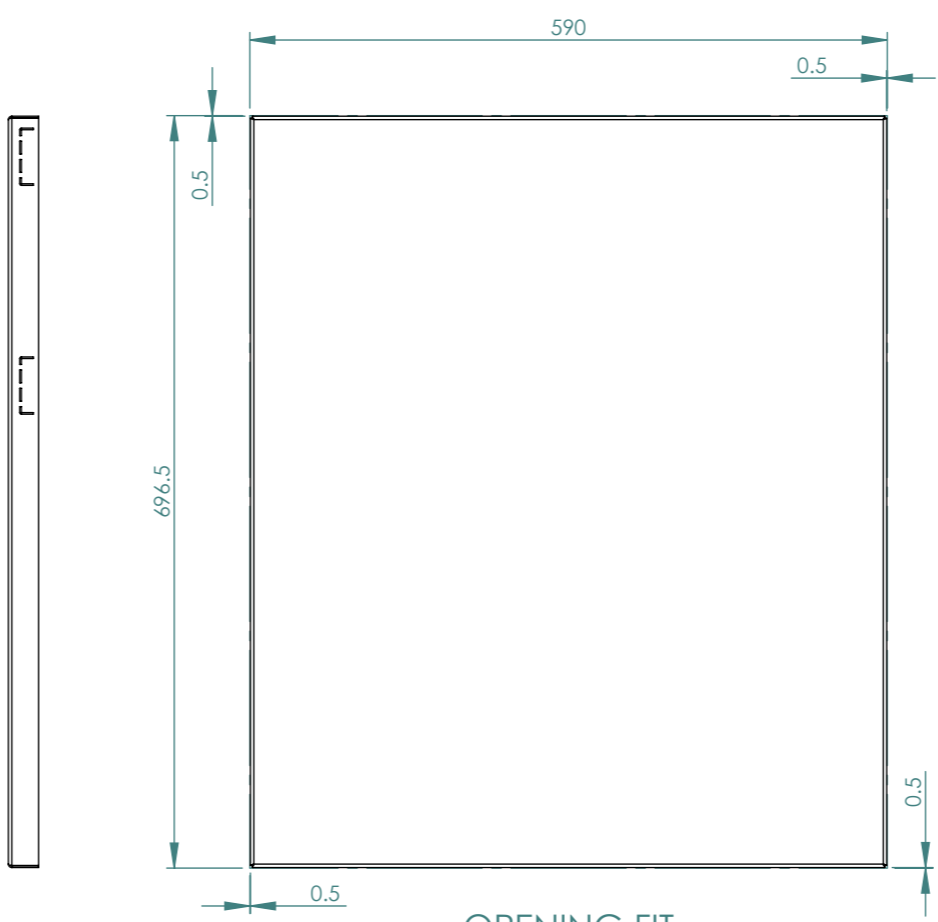
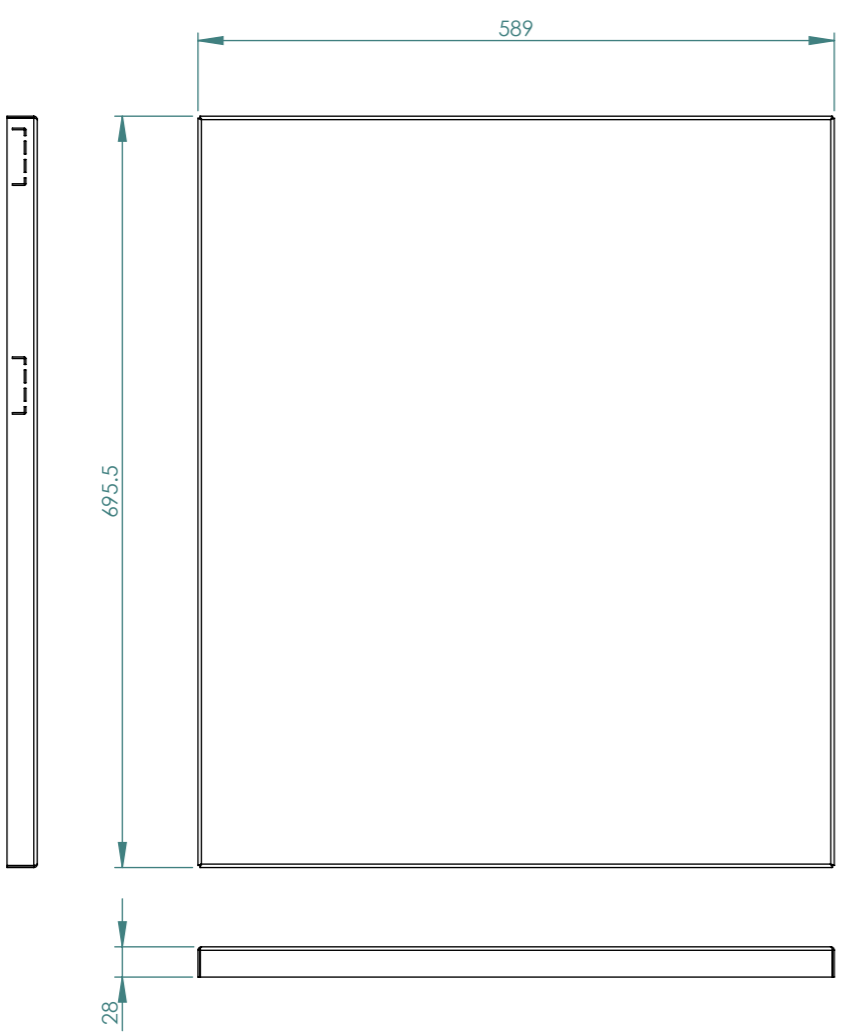
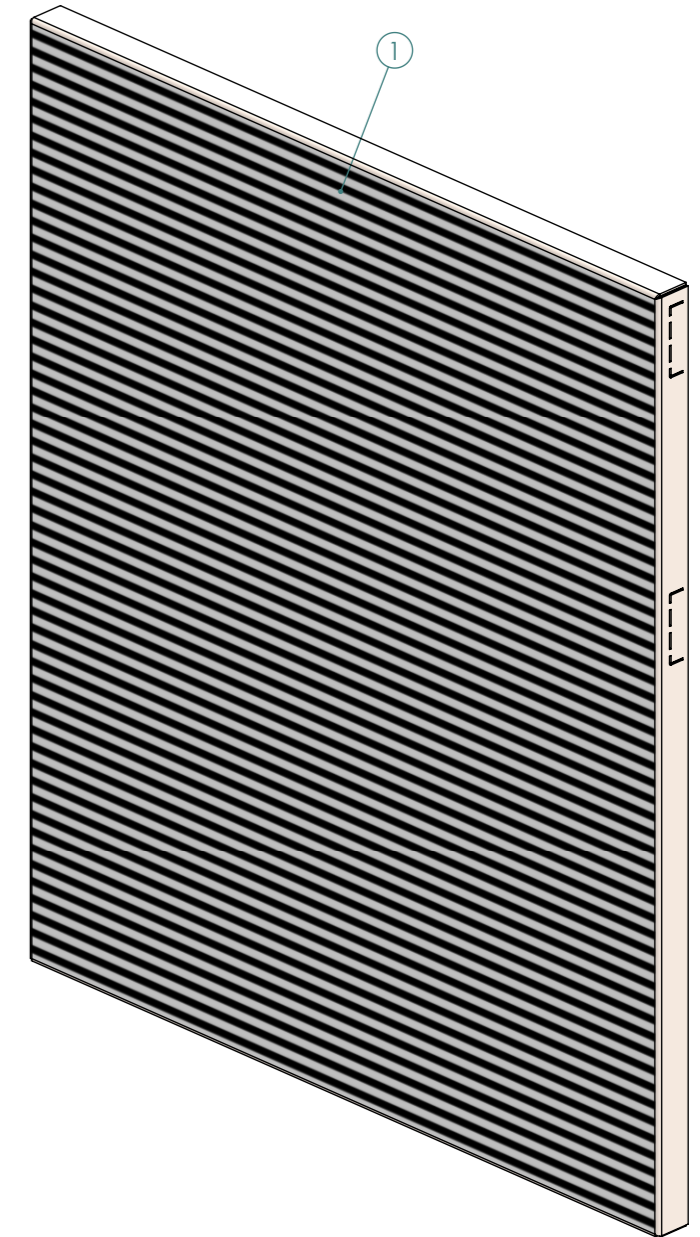
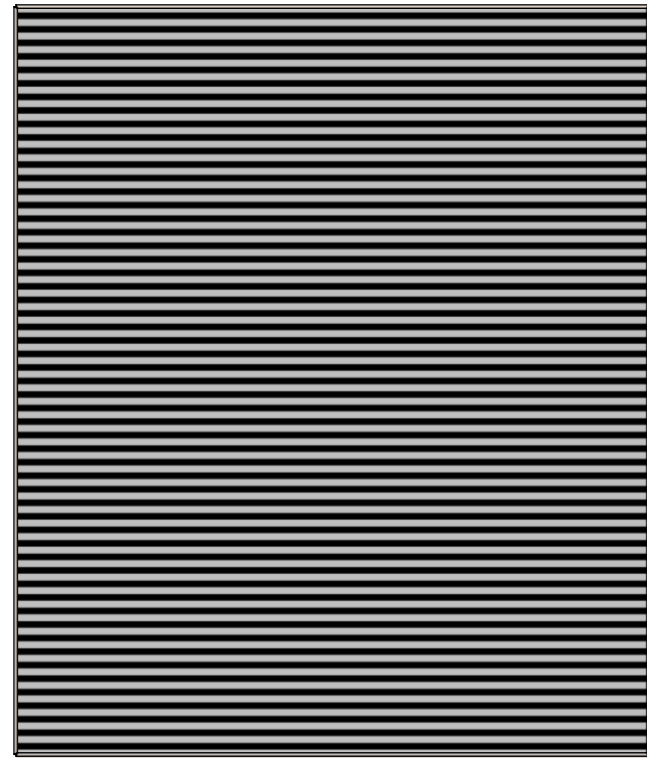

REV	DESCRIPTION	DATE	BY
C			
B			
A			
-	INITIAL RELEASE	25/07/22	LF
-	APPROVAL RELEASE	25/07/22	LF

UNLESS OTHERWISE SPECIFIED
DIMENSIONS ARE IN MILLIMETERS
TOLERANCES:
LINEAR: ±1mm
ANGULAR: ±1°
REMOVE ALL SHARP EDGES & BURRS

MATERIAL: AS SHOWN
FINISH: AS SHOWN
DO NOT SCALE DRAWING



Rowlands Metal Works
QUALITY CRAFTSMANSHIP
SINCE 1958
Unit 13/19 Heath St.
Lonsdale SA 5160
p +61 (08) 8329 6700
F +61 (08) 8329 6701
metal@rowlandsmetal.com.au
www.rowlandsmetal.com.au
ABN 33 674 549 964

CUSTOMER: XXXXXX XXXX XXXXXX
PROJECT: OPV KITCHEN GALLEY
DRAWING: XXXXX-OPV-SHIP5-3-235-A
SHEET NAME: F PANEL VERT
REV: -
A3
SHEET 18 OF 23

FOR PRODUCTION

CUT LIST (G PANEL VERT (235))

ITEM	QTY	DESCRIPTION	TH	MATERIAL	BENDS
1	1	G1 PANEL VERT	1.6	304 S/S - #4 GRAIN	4

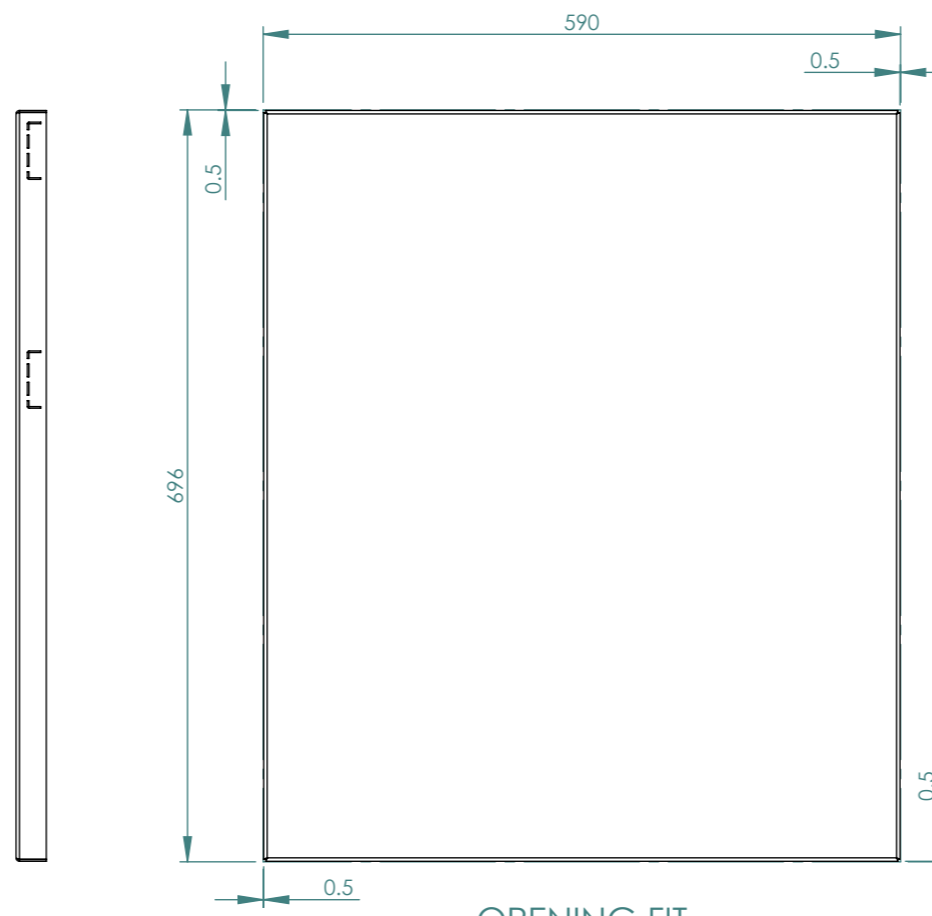
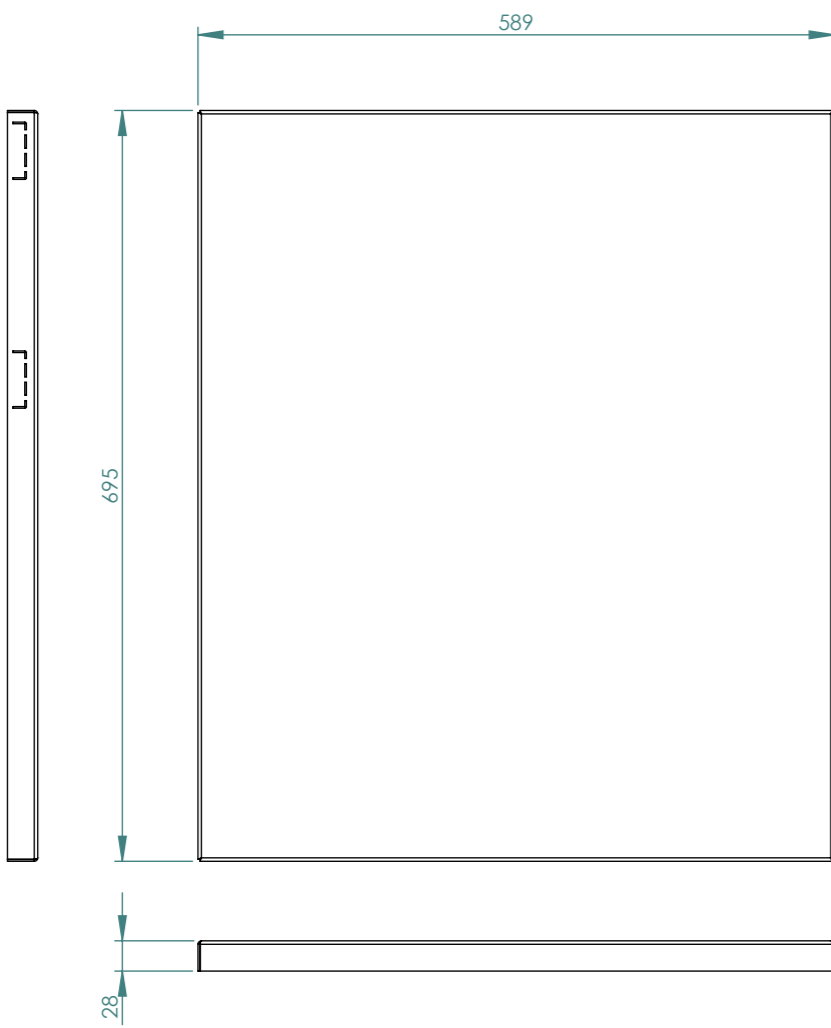
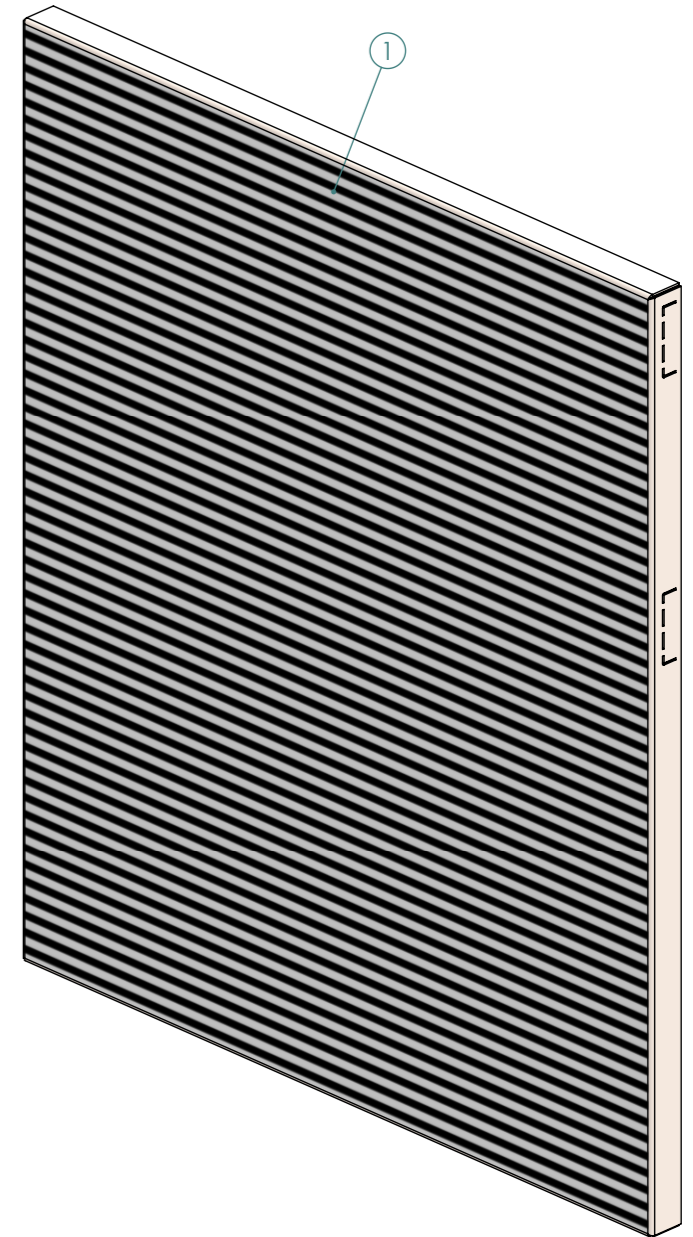
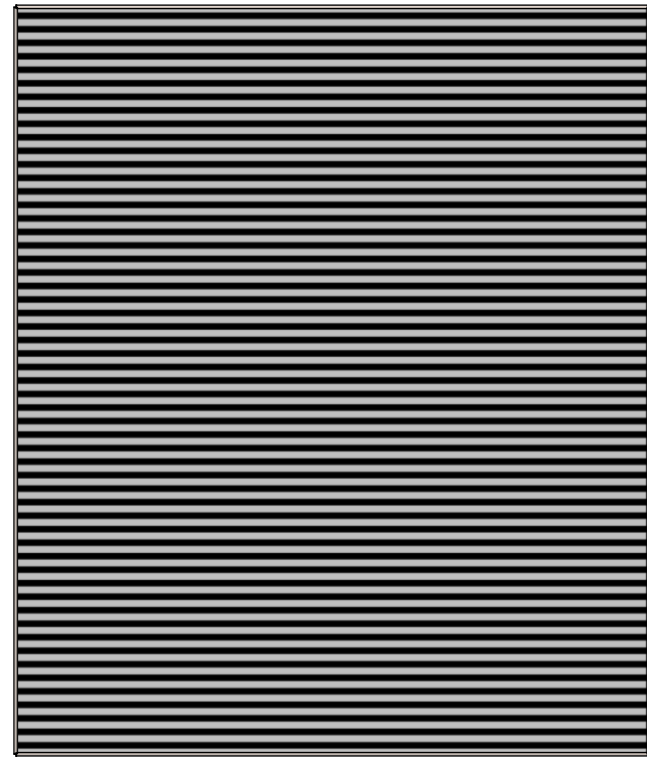

REV	DESCRIPTION	DATE	BY
C			
B			
A			
-	INITIAL RELEASE	25/07/22	LF
-	APPROVAL RELEASE	25/07/22	LF

UNLESS OTHERWISE SPECIFIED
DIMENSIONS ARE IN MILLIMETERS
TOLERANCES:
LINEAR: ±1mm
ANGULAR: ±1°
REMOVE ALL SHARP EDGES & BURRS

MATERIAL: AS SHOWN
FINISH: AS SHOWN
DO NOT SCALE DRAWING



Rowlands Metal Works
QUALITY CRAFTSMANSHIP
SINCE 1956
Unit 13/19 Heath St.
Lonsdale SA 5160
p +61 (08) 8329 6700
F +61 (08) 8329 6701
metal@rowlandsmetal.com.au
www.rowlandsmetal.com.au
ABN 33 674 549 964

CUSTOMER:	XXXXXX XXXX XXXXXX
PROJECT:	OPV KITCHEN GALLEY
DRAWING:	XXXXX-OPV-SHIP5-3-235-A
SHEET NAME:	G PANEL VERT
REV:	-
A3	
SHEET 19 OF 23	

CUT LIST (H SHELF (235))					
ITEM	QTY	DESCRIPTION	TH	MATERIAL	BENDS
1	1	H1 SHELF	1.6	304 S/S - #4 GRAIN	8

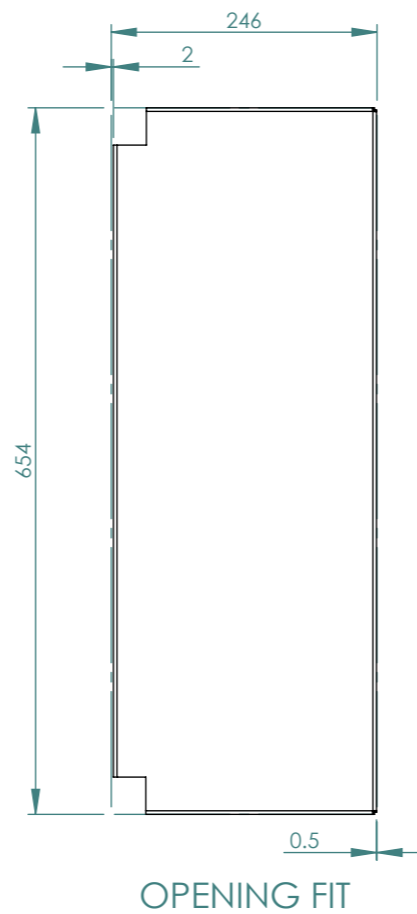
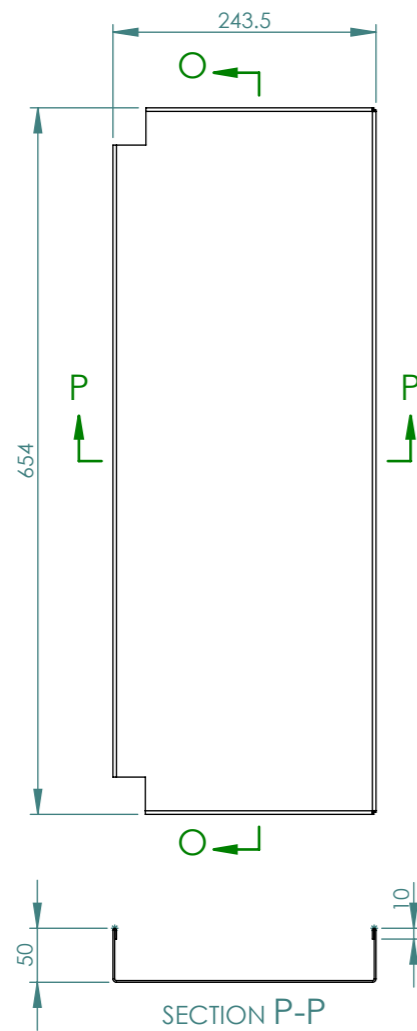
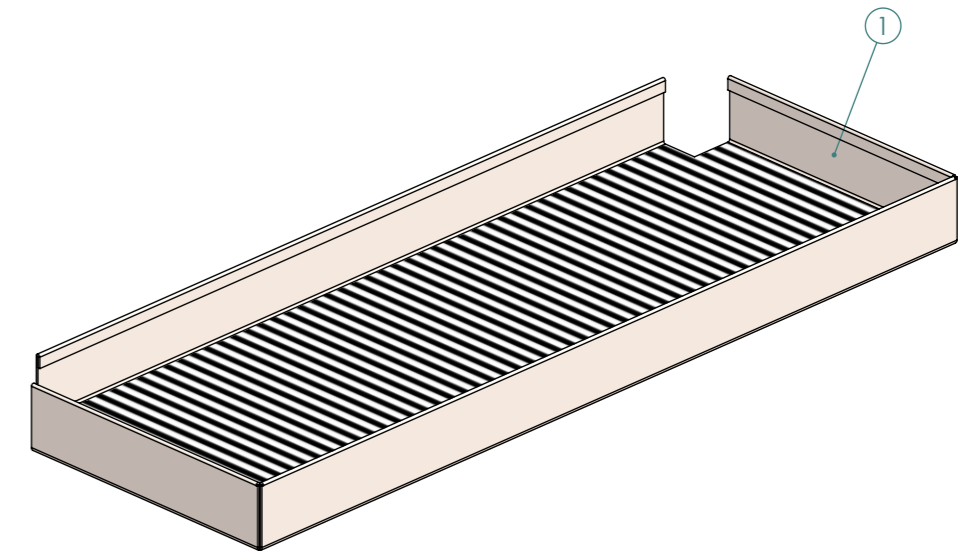
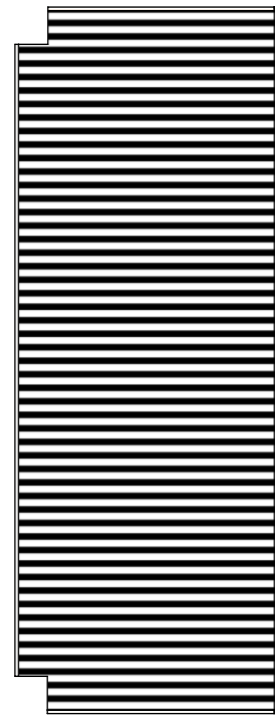

REV	DESCRIPTION	DATE	BY
C			
B			
A			
-	INITIAL RELEASE	25/07/22	LF
-	APPROVAL RELEASE	25/07/22	LF

NAME	DATE
DRAWN LF	00/00/00
CHK'D AK	00/00/00
APPV'D MK	00/00/00

MATERIAL:	AS SHOWN
FINISH:	AS SHOWN
DO NOT SCALE DRAWING	



Rowlands Metal Works
 QUALITY CRAFTSMANSHIP
 SINCE 1956

Unit 13/19 Heath St.
 Lonsdale SA 5160
 p +61 (08) 8329 6700
 F +61 (08) 8329 6701
 metal@rowlandsmetal.com.au
 www.rowlandsmetal.com.au
 ABN 33 674 549 964

CUSTOMER:	XXXXXX XXXX XXXXXX
PROJECT:	OPV KITCHEN GALLEY
DRAWING:	XXXXX-OPV-SHIP5-3-235-A
SHEET NAME:	H SHELF
REV:	-
A3	
SHEET 20 OF 23	

1 2 3 4 5 6 7 8

A B C D E F

CUT LIST (I DOOR (235))					
ITEM	QTY	DESCRIPTION	TH	MATERIAL	BENDS
1	1	I1 DOOR LEFT OUTER	1.6	304 S/S - #4 GRAIN	4
2	1	I2 DOOR LEFT INNER	1.6	304 S/S - #4 GRAIN	8
3	1	PADDLE LATCH			
4	1	CONTINUOUS HINGE			

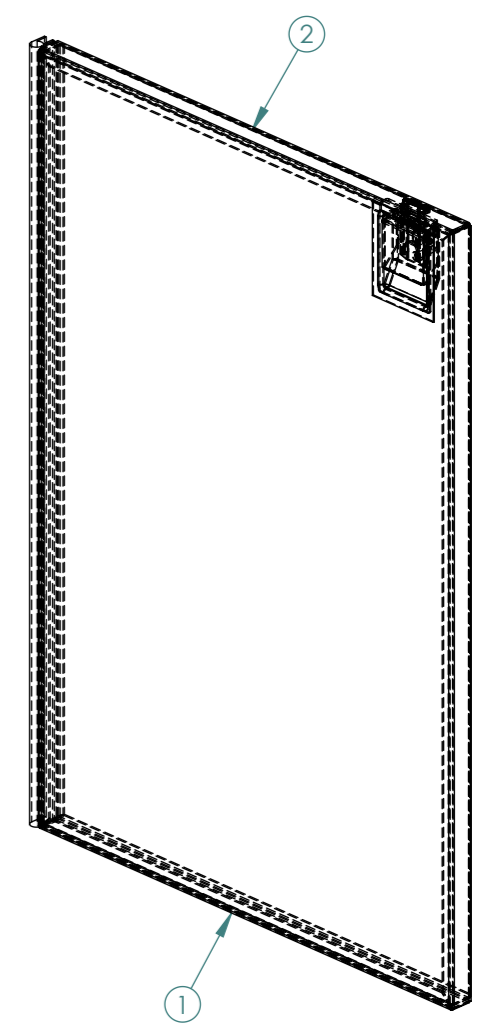
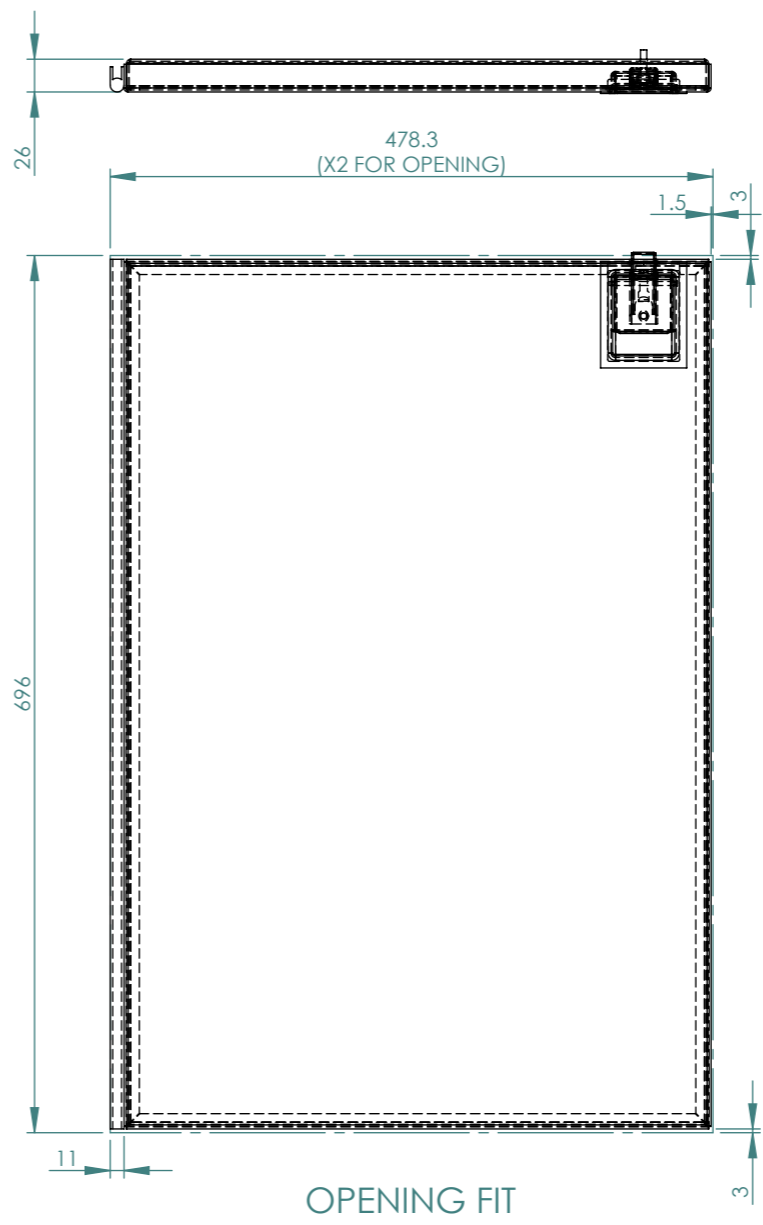
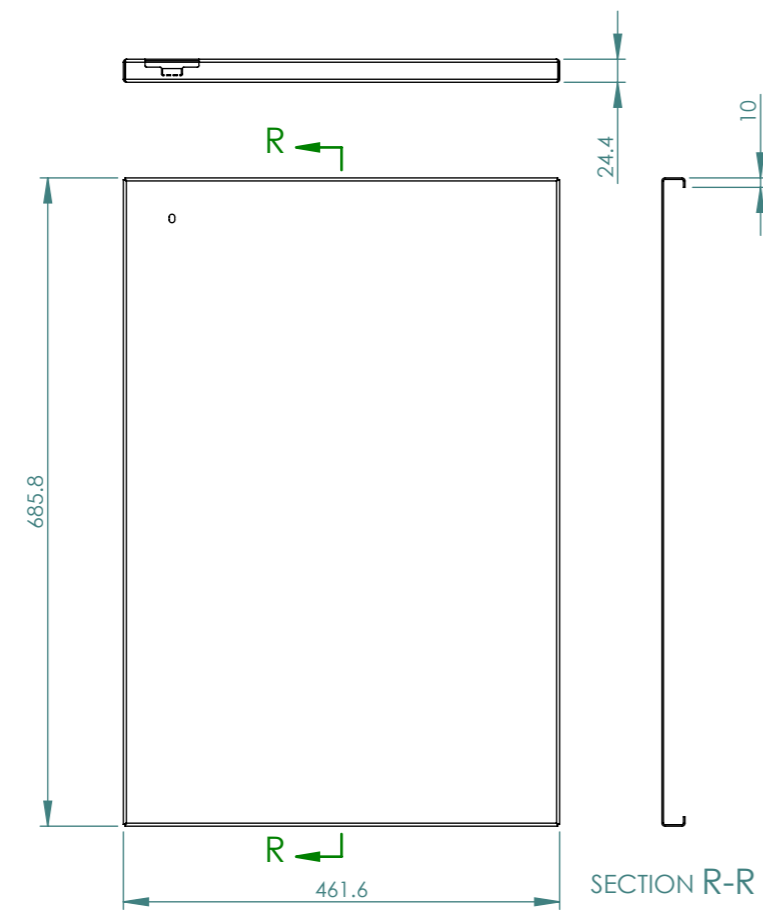
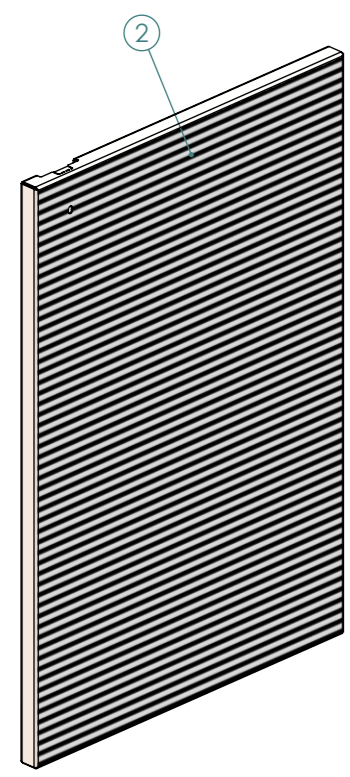
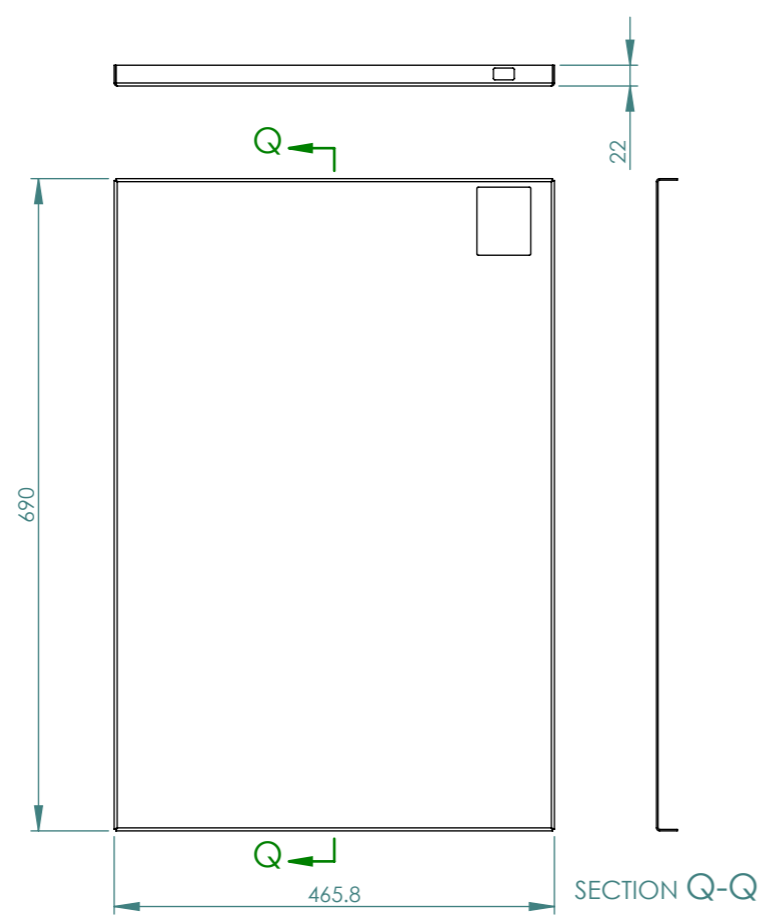
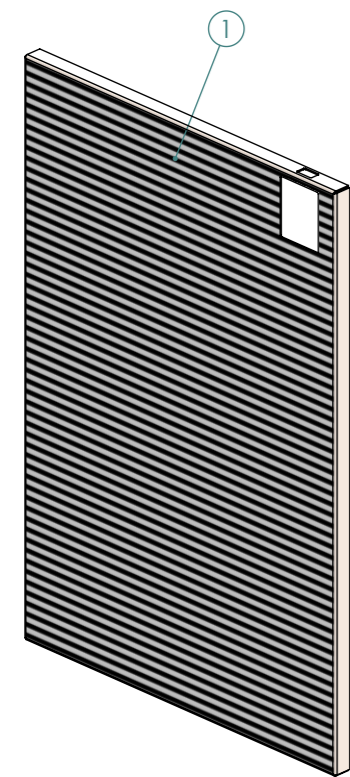

REV	DESCRIPTION	DATE	BY
C			
B			
A			
-	INITIAL RELEASE	25/07/22	LF
-	APPROVAL RELEASE	25/07/22	LF

UNLESS OTHERWISE SPECIFIED
DIMENSIONS ARE IN MILLIMETERS
TOLERANCES:
LINEAR: ±1mm
ANGULAR: ±1°
REMOVE ALL SHARP EDGES & BURRS

MATERIAL: AS SHOWN
FINISH: AS SHOWN
DO NOT SCALE DRAWING



**Rowlands
Metal Works**
QUALITY CRAFTSMANSHIP
SINCE 1956

Unit 13/19 Heath St.
Lonsdale SA 5160
p +61 (08) 8329 6700
F +61 (08) 8329 6701
metal@rowlandsmetal.com.au
www.rowlandsmetal.com.au
ABN 33 674 549 964

CUSTOMER: XXXXXX XXXX XXXXXX	REV: -	A3
PROJECT: OPV KITCHEN GALLEY	SHEET 21 OF 23	
DRAWING: XXXXX-OPV-SHIP5-3-235-A		
SHEET NAME: I DOOR LEFT		

CUT LIST (J DOOR (235))

ITEM	QTY	DESCRIPTION	TH	MATERIAL	BENDS
1	1	J1 DOOR RIGHT OUTER	1.6	304 S/S - #4 GRAIN	4
2	1	J2 DOOR RIGHT INNER	1.6	304 S/S - #4 GRAIN	8
3	1	PADDLE LATCH			
4	1	CONTINUOUS HINGE			

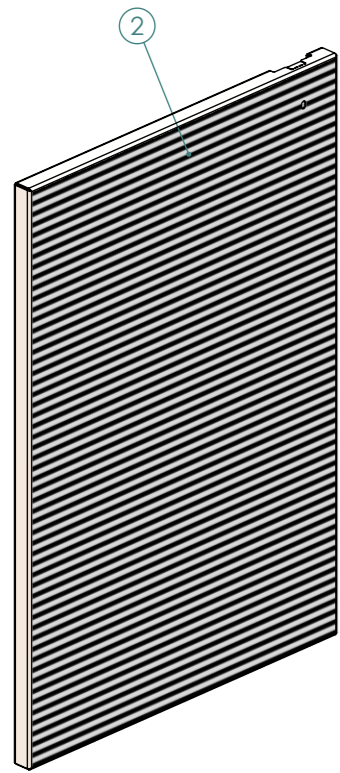
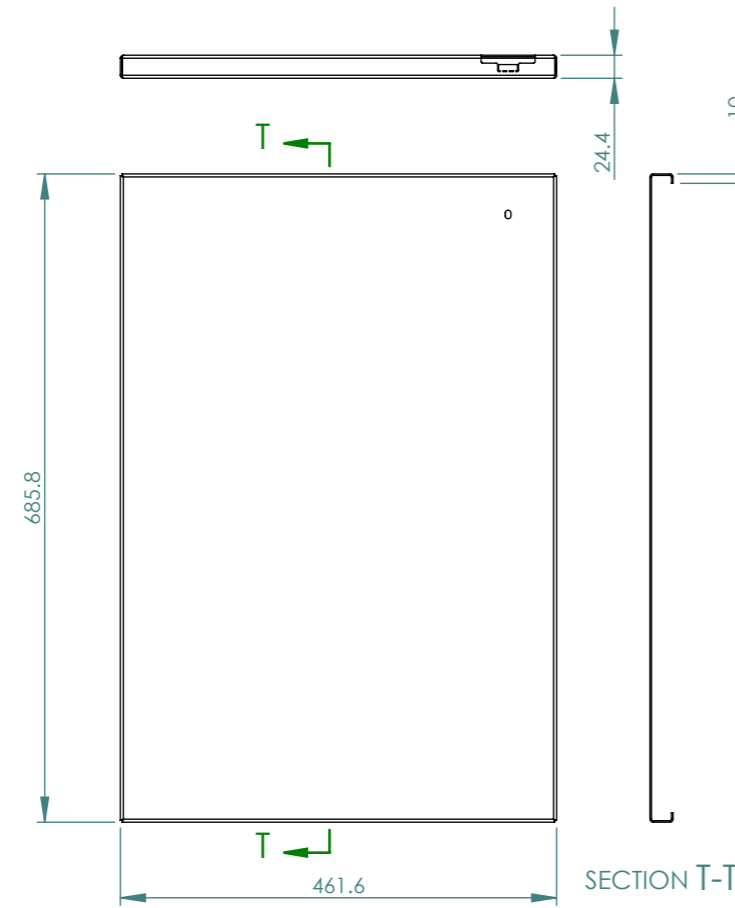
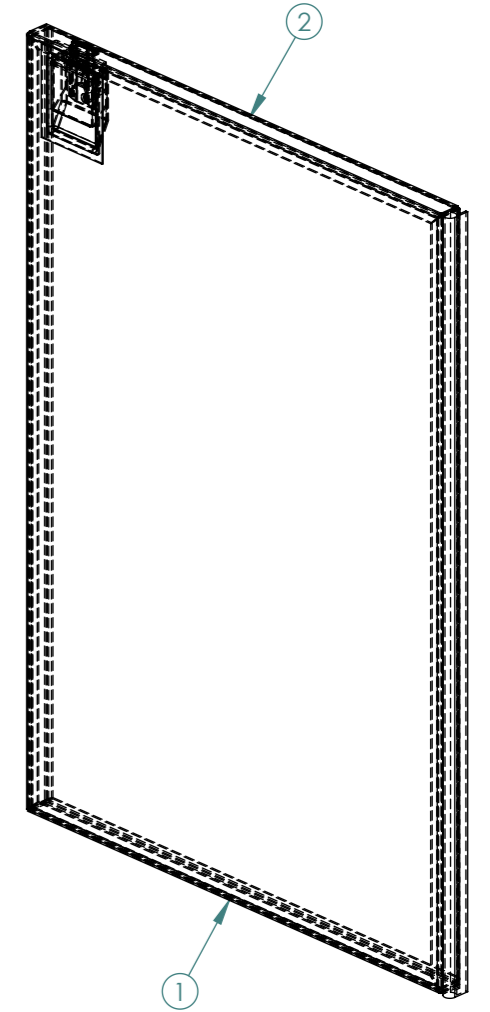
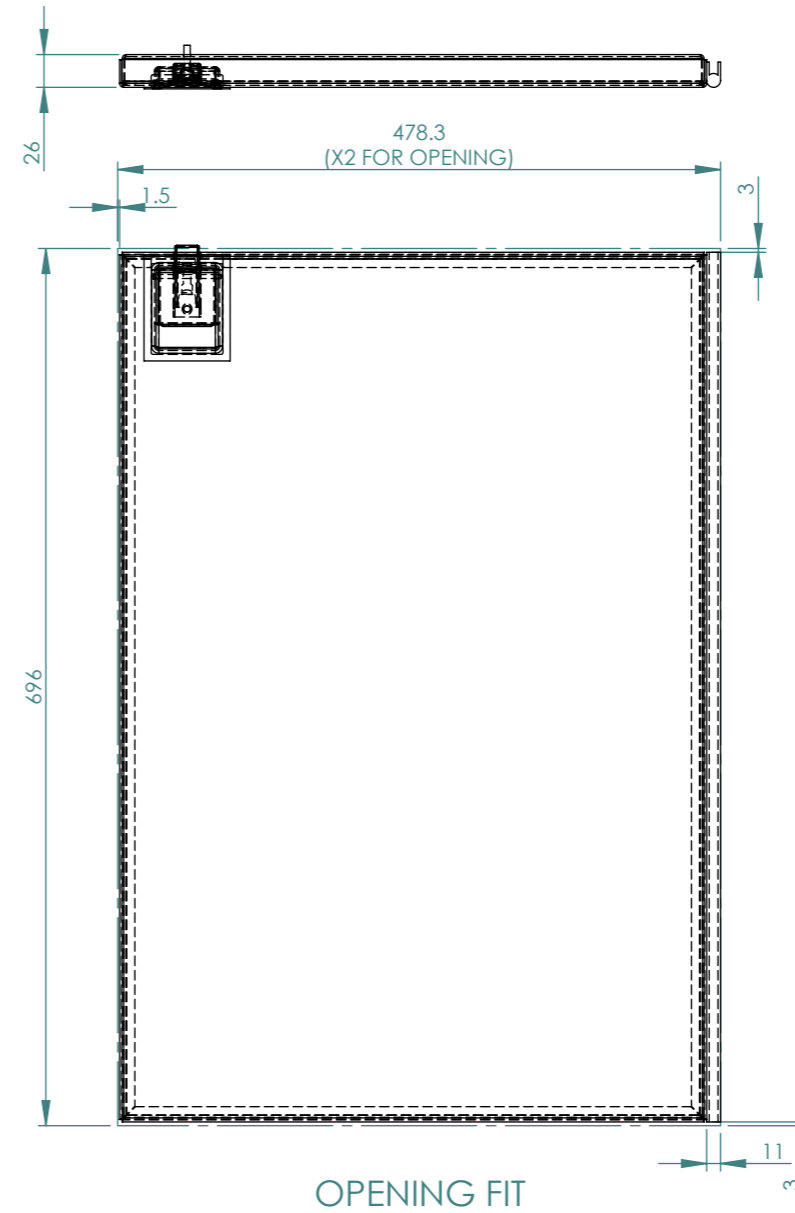
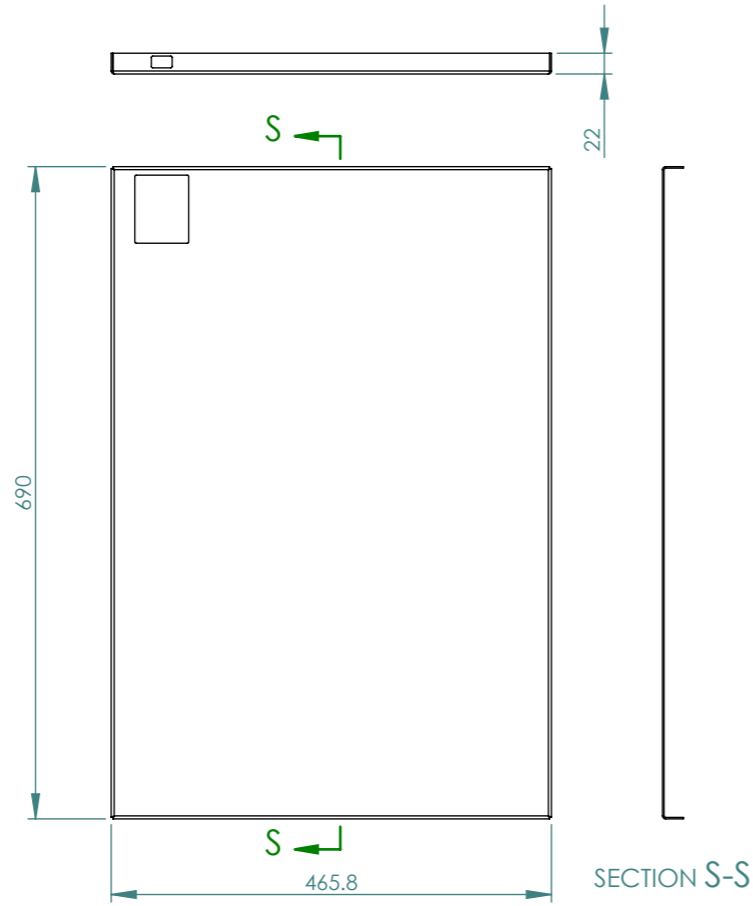
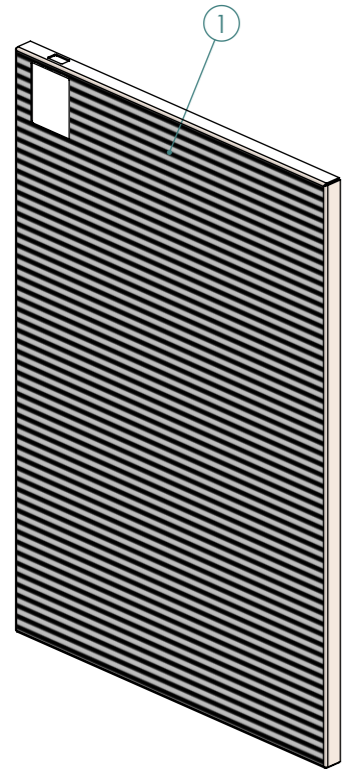

REV	DESCRIPTION	DATE	BY
C			
B			
A			
-	INITIAL RELEASE	25/07/22	LF
-	APPROVAL RELEASE	25/07/22	LF

NAME	DATE
DRAWN LF	00/00/00
CHK'D AK	00/00/00
APPV'D MK	00/00/00

UNLESS OTHERWISE SPECIFIED
DIMENSIONS ARE IN MILLIMETERS
TOLERANCES:
LINEAR: ±1mm
ANGULAR: ±1°
REMOVE ALL SHARP EDGES & BURRS

MATERIAL: AS SHOWN
FINISH: AS SHOWN

DO NOT SCALE DRAWING



Rowlands Metal Works
QUALITY CRAFTSMANSHIP SINCE 1956
Unit 13/19 Heath St.
Lonsdale SA 5160
p +61 (08) 8329 6700
F +61 (08) 8329 6701
metal@rowlandsmetal.com.au
www.rowlandsmetal.com.au
ABN 33 674 549 964

CUSTOMER: XXXXXX XXXX XXXXXX	REV: -	A3
PROJECT: OPV KITCHEN GALLEY	SHEET 22 OF 23	
DRAWING: XXXXX-OPV-SHIP5-3-235-A		
SHEET NAME: J DOOR RIGHT		

FOR PRODUCTION

CUT LIST (K DRAWER (235))

ITEM	QTY	DESCRIPTION	TH	MATERIAL	BENDS
1	1	K1 DRAWER FRONT OUTER	1.6	304 S/S - #4 GRAIN	4
2	1	K2 DRAWER FRONT INNER	1.6	304 S/S - #4 GRAIN	8
3	1	K3 DRAWER BODY	1.2	304 S/S - #4 GRAIN	11
4	2	XXXX-OPV-DRAW-RUN-D			
5	1	PADDLE LATCH			
6	2	DRAWER RUNNER			

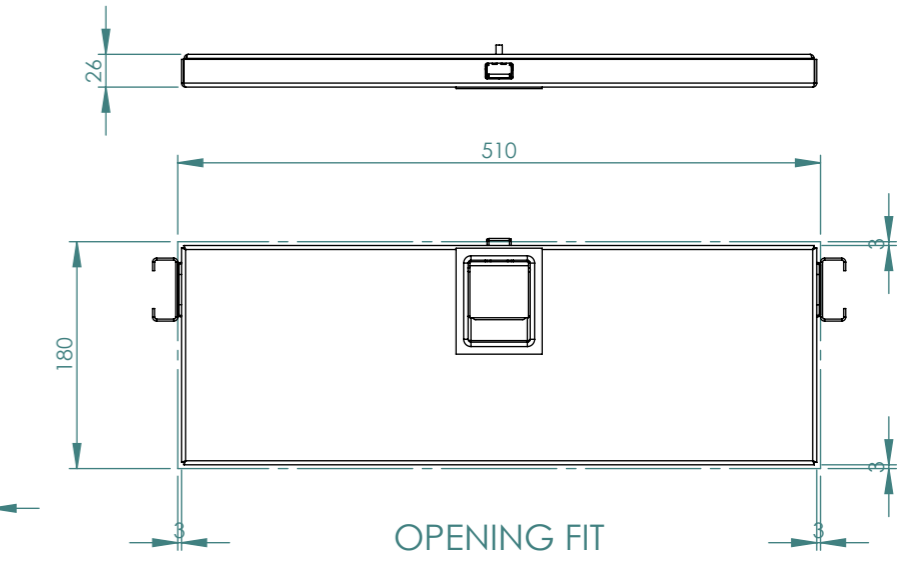
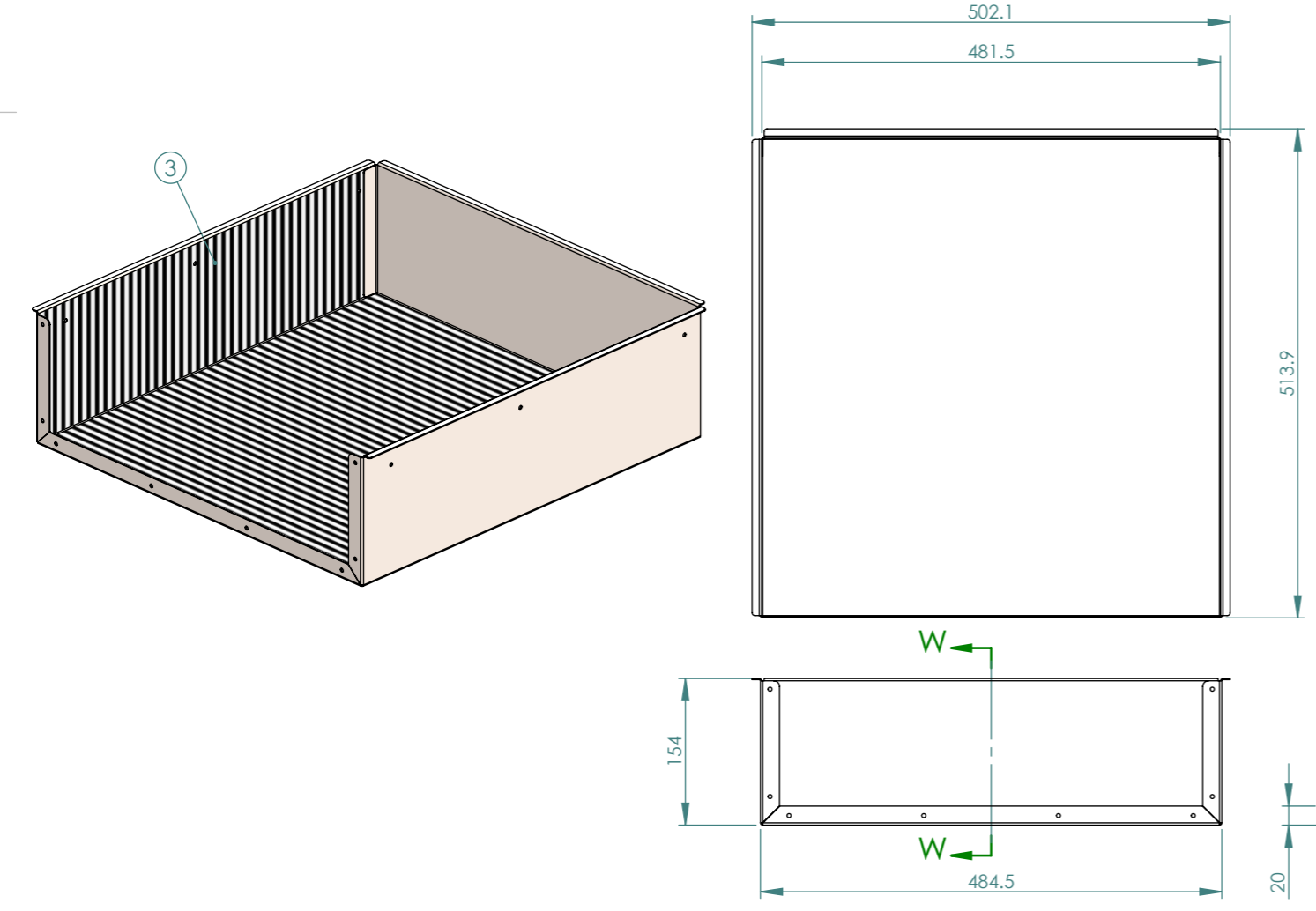
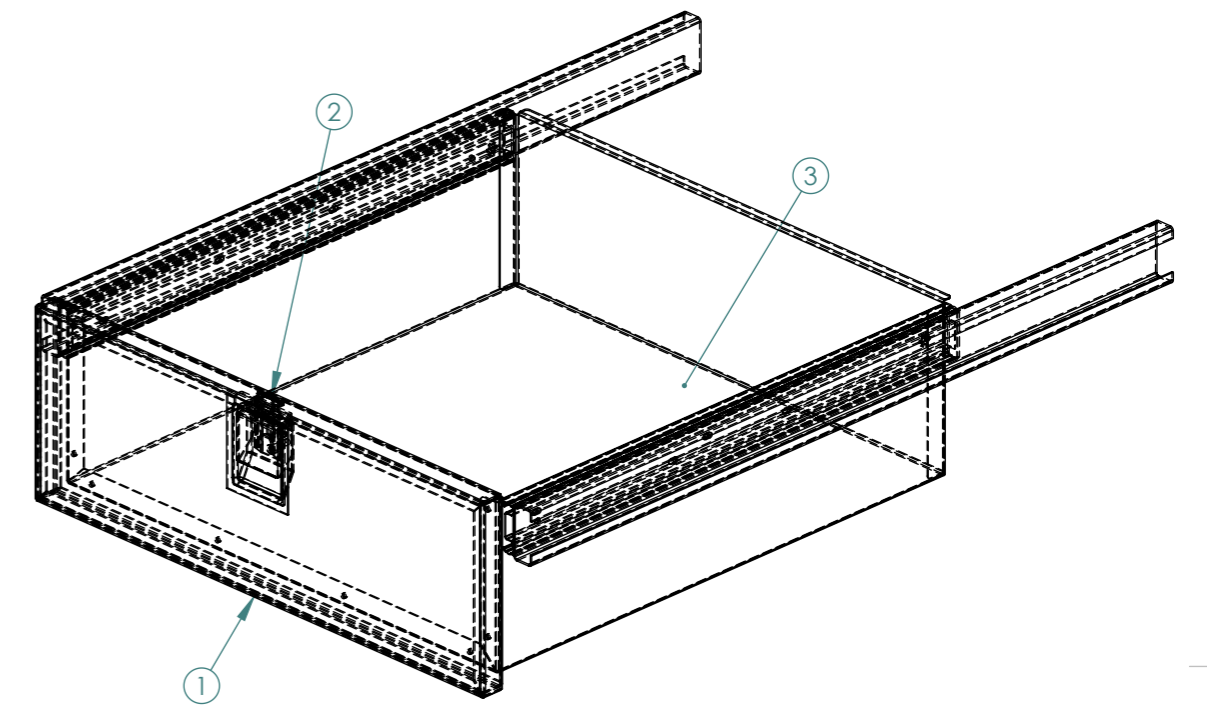
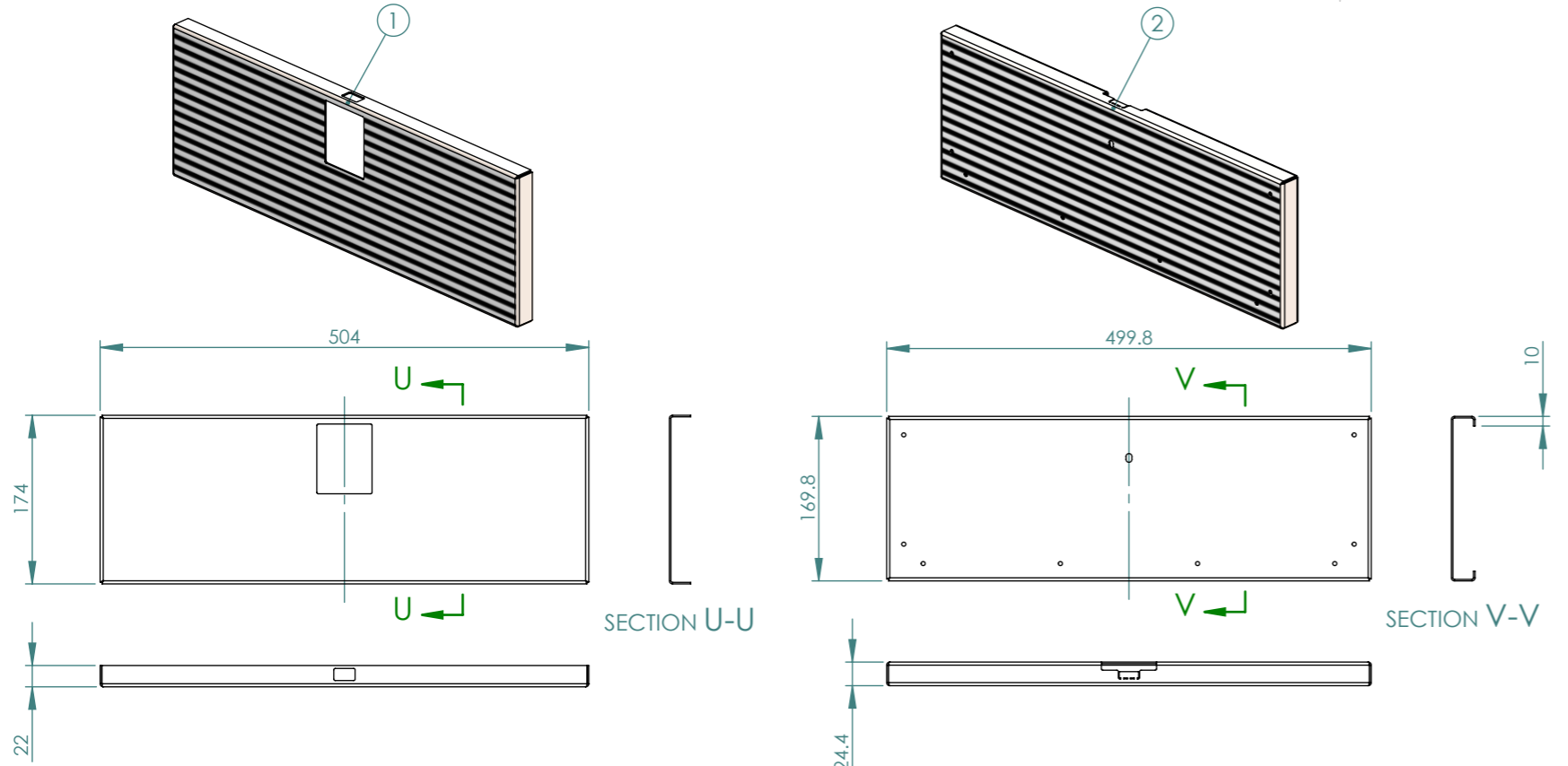

REV	DESCRIPTION	DATE	BY
C			
B			
A			
-	INITIAL RELEASE	25/07/22	LF
-	APPROVAL RELEASE	25/07/22	LF

NAME	DATE
DRAWN LF	00/00/00
CHK'D AK	00/00/00
APPV'D MK	00/00/00

UNLESS OTHERWISE SPECIFIED
DIMENSIONS ARE IN MILLIMETERS
TOLERANCES:
LINEAR: ±1mm
ANGULAR: ±1°
REMOVE ALL SHARP EDGES & BURRS

MATERIAL: AS SHOWN
FINISH: AS SHOWN

FOR PRODUCTION

DO NOT SCALE DRAWING

Rowlands Metal Works
QUALITY CRAFTSMANSHIP SINCE 1956

Unit 13/19 Heath St.
Lonsdale SA 5160
p +61 (08) 8329 6700
f +61 (08) 8329 6701
metal@rowlandsmetal.com.au
www.rowlandsmetal.com.au
ABN 33 674 549 964

CUSTOMER: XXXXXX XXXX XXXXXX	REV: -	A3
PROJECT: OPV KITCHEN GALLEY	SHEET 23 OF 23	
DRAWING: XXXXX-OPV-SHIP5-3-235-A		
SHEET NAME: K DRAWER		